



**cofem, s.a.**  
1973

**TECHNICAL CATALOGUE**



**ALGORITHMIC SYSTEM  
CONVENTIONAL SYSTEM  
ACCESORIES**

[www.cofem.com](http://www.cofem.com)



**ADDRESSABLE  
SYSTEM**



**CONTROL  
PANELS**



**DETECTORS  
& MODULES**

**SOFTWARE**









COFEM ALGORITHMIC ADDRESSABLE FIRE DETECTION SYSTEM

The Algorithmic addressable Fire Detection System represents the most modern technology in fire detection and constitutes a natural evolution from the Identifiable Detection System towards equipment that not only is able to identify the element that produces the alarm (sensor or call point), but that also allows for the total configuration of detection parameters (alarm levels, sensibility,...) as well as the adaptation to the environmental conditions and the degree of dust in the sensor.

In the Cofem Algorithmic addressable Detection System, the loop elements (sensors, manual call points, relay modules, masters, analogue sounders and technical signal module) have the property of being auto-identifiable, that is to say, all of them can be installed with no need for prior manual encoding, facilitating enormously the assembly and subsequent modifications to the installation.

The Algorithmic addressable Detection System is based on the measurement and transmission of the instant value of the monitored magnitude (smoke, temperature or monoxide concentration), for their subsequent processing in the control panel, which will consider the alert or standby status of the sensor. Each sensor incorporates a microprocessor responsible for the digitalization of the analogue value read in the sensor, for transmission of this value to the control panel and for identification of the sensor.

The main difference between the conventional and analogical detection systems lies in that for the first the Voltage delivered by the transducer is compared with a predetermined and fixed threshold ( $V_{alarm}$ ), obtaining from that comparison the system in standby or system in alarm status.

In the Algorithmic addressable Detection System, on the contrary, the control panel gathers the readings from each sensor and determines the status thereof according to these readings, any previous readings (history), the pre-programmed parameters and on the decision algorithm, being possible to act on the detection parameters, as well as, for example, the alarm threshold.

Each sensor on the Cofem Algorithmic addressable Detection System transmits its value to the control panel with a regularity of less than 10 seconds.

The following table shows the values of equivalence of the elements connected to analogue control panels and operating limits.

Maximum devices per control panel				
Referece	Description	Equivalence Logic Relay	Maximum devices per loop	
			LYON / ZAFIR	C-Lyon
A50SHCOI	Multisensor optical-thermic-monoxide	---	226	99
A50SHI	Sensor optical-thermic with isolator	---	226	99
A50SI	Sensor optical with isolator	---	226	99
A50HI	Sensor thermic with isolator	---	226	99
A50SH	Sensor optical-thermic	---	226	99
A50S	Sensor optical	---	226	99
A50H	Sensor thermic	---	226	99
A30XHCOI	Multisensor optical-thermic-monoxide	---	226	99
A30XHA	Algorithmic optical-thermic sensor	---	226	99
A30XHAS	Algorithmic sensor optical algorithmic	---	226	99
A30XHSA	Algorithmic sensor thermic algorithmic	---	226	99
PUCAY	Algorithmic manual call point	---	226	99
MSTAY	Technical signals module	---	226	76
MSTAY8	Technical 8 signals module (note: power drain equivalent to 8 devices)	---	28	12
KMAY	Conventional zone master module	---	199	76
KMAY32	Conventional zone master module up to 32 conventional detectors	---	226	99
MYOA	Technical signal and module relay	1	32	16
MDA1Y	One Relay module	1	32	16
MDA2Y	Two Relays module	2	16	8
MDA2YLT	Dry Contact Two Relays module	2	16	8
KABY	Loop isolator	---	226	99
SIRAY	Algorithmic Siren	1	32	16
SIRAYL	Algorithmic Siren with light	1	32	16
SIRAY+BSLC	Algorithmic Siren with light certified with EN 54-23	1	19	10
A50ZSLDR	Sound and light for A50 detector socket	1	32	16
A50ZSDDR	Sound for A50 detector socket	1	32	16
A30ZSLDR	Sound and light for A30 detector socket	1	32	16
A30ZSDDR	Sound for A30 detector socket	1	32	16
<b>Control Panel Limit:</b>				
<b>LYON Control Panel</b>		<b>ZAFIR Control Panel</b>		<b>C-Lyon Control Panel</b>
a) 226 elements and 32 logic relays per loop b) 20 loops and 199 logic relays per panel		a) 226 elementos and 32 logic relays per loop		a) 99 elements and 16 logic relays per loop

Limit elements per loop and per fire control panel (Lyon, Zafir and Compact Lyon)



# COFEM REMOTE

## Communication system



The Cofem Remote system of the Lyon Remote, Compact Lyon and Zafir algorithmic-addressable control panels allows them to be connected from anywhere, making it possible to change the configuration, view maintenance data and manage online.

Thus, the user can interact with the control panel during starting up and subsequently manage maintenance planning or provide online real-time support to customers from their offices or anywhere else by means of a tablet, smartphone or PC with internet access.

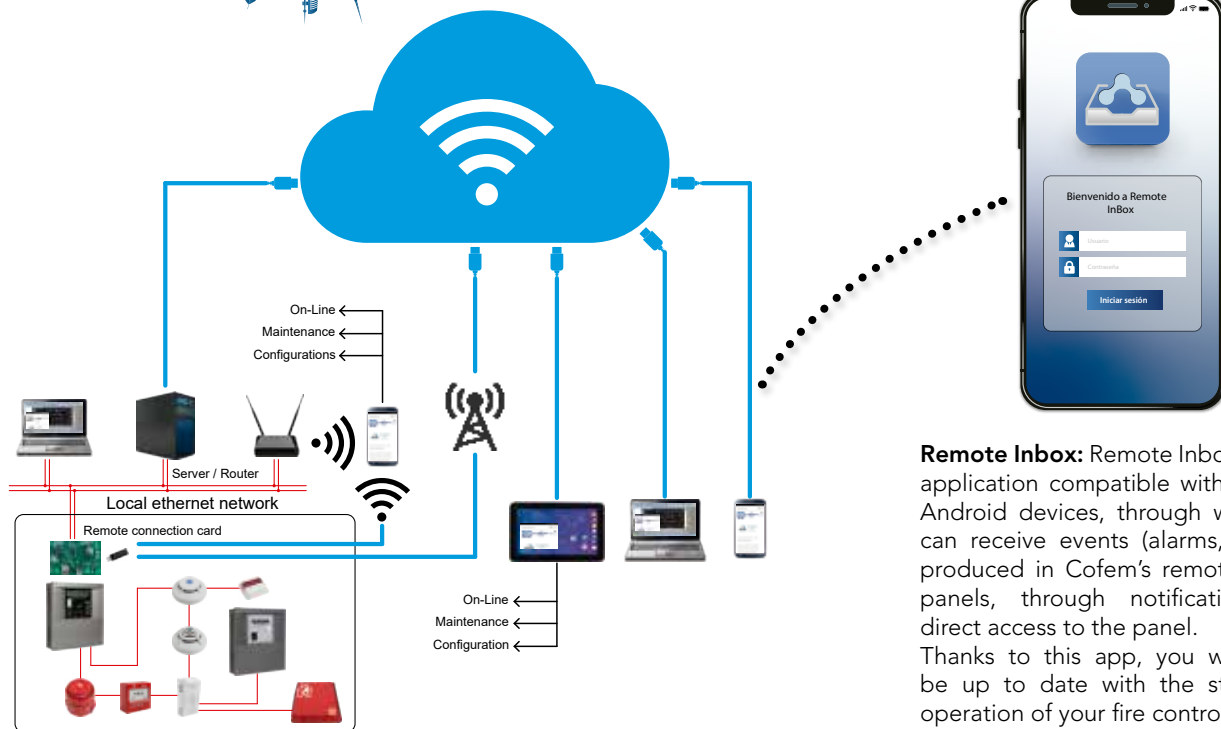

**Remote Inbox:** Remote Inbox: Mobile application compatible with iOS and Android devices, through which you can receive events (alarms, faults,...) produced in Cofem's remote control panels, through notifications and direct access to the panel. Thanks to this app, you will always be up to date with the status and operation of your fire control panel, in an easy and intuitive way.

**NOTE:** The functions offered in the product will depend on its version

Technical characteristics:

- View and act on the status of the control panel during the installation/starting up of the system.
- View and act on the status of the control panel in the customer's local network.
- View and act on the status of the control panel during maintenance.
- Management of events and alerts



# COFEM RMS

## Remote management system



Remote Touch Display to be installed in the premises or building that allows the management of the incidents of the fire detection and alarm system with a very reduced training of the personnel.

The display is designed to be placed in an accessible place for the personnel responsible for the installation, allowing a very simple, clear and intuitive visualisation of the alarms, faults and disconnections of the fire detection and alarm system.

In case of events, the user can perform immediate predetermined actions according to the reported events, such as resetting the event, stopping the sounders or evacuation.

Due to its simplicity in the presentation of information and action on the events, the staff needs very little training to use it, which makes it very practical, useful and effective in emergency and stress situations.

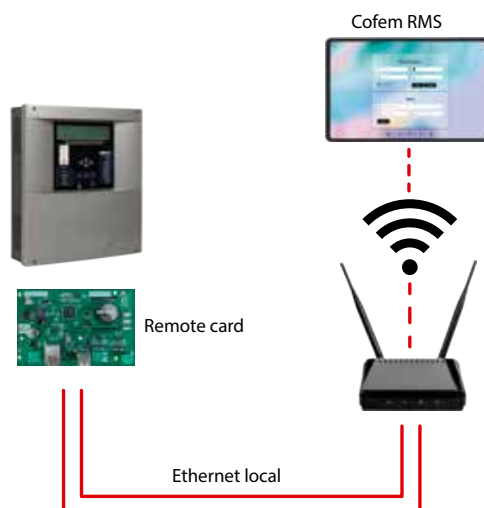



# LYON REMOTE

## Addressable algorithmic control panel



The Lyon algorithmic addressable Control Panel is EN 54-2 and EN 54-4 standard certified according to the latest CE Directives/Regulation and can successfully overcome difficult environmental conditions, electrical interferences, electromagnetic radiate upsets, vibrations, etc.

The algorithmic addressable Detection System is able to identify the device which produces the alarm or fault (sensor or call point), and allows the total configuration of the detection parameters (alarm levels, sensibility...) as well as the adaptation to the environmental conditions and the degree of dust in the sensor.

In the Cofem algorithmic addressable System, the loop elements (sensors, manual call points, relay modules, masters, analogue sounders and technical signal modules) have the property of being auto-identifiable, that is to say, all of them can be installed with no need for prior manual encoding, facilitating enormously the assembly and subsequent modifications to the installation.

### Features:

- Control panel configurable and expandable up to 8 loops (226 points per loop).
- Expandable up to 20 loops with an additional cabinet.
- All the points are supervised by the control panel, except the loop isolator KABY.
- Capacity for 199 configurable relays per control panel.
- Can hold up to 99 zones per panel.
- Registry with capacity of 3308 events with date and time.
- Relay configuration with activation of 1, 2 or 3 alarm detectors.
- Relay activation auto-configuration function.
- Allows the configuration of visual and/or sound devices of the detector bases as loop powered relays.
- Delay of supervised sounder output programmable between 0 to 10 minutes, identified as S1.
- Alarm output as free voltage relay not supervised, identified as S2.
- Failure output, delayed and supervised, identified as S3.
- Allowed to connect addressable sounders in the loop.
- Evacuation push-button.
- Backlit LCD display with 4 lines and 40 characters.
- Incorporates multiple languages by default (Spanish, English, French, Portuguese, etc).
- Configurable with the I-Link software.
- Access to the control panel keyboard introducing a numeric code.
- Allows connection of up to 15 repeaters and/or 15 control panels in network.
- MODBUS (on specific request).
- CRI functionality on demand.
- Cofem Remote.
- Size: 424 x 330 x 140 mm.
- Certified according to EN 54-2 and EN 54-4 and CE mark according to the European Regulation of Construction Products (UE) N°305/2011.

### TECHNICAL FEATURES

Input voltage	110/230 Vac 50/60Hz	Maximum current per loop	500 mA / 26 a 32V/DC
Output voltage	21V Nominal	Communications port	USB 2.0/1.1 type B or RS232 / RS485
Min/max. consumption	80/150W at 230VAC		
Power fuse	8 A	Environmental conditions	-10°C+50°C 20%-95% RH
Battery charger	Yes	Size	424 x 330 x 140 mm
Devices per loop	226	Weight (without batteries)	7,4 Kg
Power supply	5 A	Standard	EN 54 parts 2 and 4
Fuse S3	1 A	Fuse S1	2 A
IP protection	IP 30	Fuse output 30V	2 A



# ZAFIR

## Addressable algorithmic control panel

REMOTE OPTION



The Zafir Algorithmic addressable Control Panel is EN 54-2 and EN 54-4 according to the European Regulation of Construction Products.

The new development of Zafir control panel, allow integration of all the functionality of an addressable algorithmic system in a reduced-dimension cabinet with capacity up to 452 detectors in 2 loops.

The control panel is totally compatible with the Lyon system, highlighting that loop elements (sensors, manual call points, relay modules, masters, analogue sounders and technical signal modules) have the property of being auto-identifiable, that is to say, all of them can be installed with no need for prior manual encoding, facilitating enormously the assembly and subsequent modifications to the installation.

Features:

- Control panel configurable with 1 or 2 loops.
- Loop capability 226 points.
- All the points are supervised by the control panel, except the loop isolator KABY.
- Capacity for 64 configurable relays per control panel.
- Can hold up to 99 zones per panel.
- Registry with capacity of 6601 events with date and time.
- Relay configuration with activation of 1, 2 or 3 alarm detectors.
- Relay activation auto-configuration function.
- Allows the configuration of visual and/or sound devices of the detector bases as loop powered relays.
- Delay of supervised sounder output programmable between 0 to 10 minutes, identified as S1.
- Alarm output as free voltage relay not supervised, identified as ALARM.
- Fault output, delayed and supervised, identified as FAULT.
- Allowed to connect addressable sounders in the loop.
- Evacuation push-button.
- Backlit LCD display with 4 lines and 40 characters.
- Incorporates multiple languages by default (Spanish, English, French, Portuguese, etc).
- Configurable with the I-Link software.
- Access to the control panel keyboard introducing a numeric code.
- Allows connection of up to 15 repeaters and/or 15 control panels in network.
- Cofem Remote (on specific request).
- CRI functionality on demand.
- Size: 363 x 331 x 96 mm.
- Certified according to EN-54-2 and EN 54-4 and CE mark according to the European Regulation of Construction Products (UE) N°305/2011.

### TECHNICAL FEATURES

Input Voltage	110/230 Vac 50/60Hz	Maximum current per loop	500 mA / 24 to 36V/DC
Output Voltage	24V Nominal	Communications port	USB 2.0/1.1 type B & RS485
Maximum Consumption	70 VA to 230V/AC	Environmental conditions	-10°C+50°C 20%-95% RH
Battery Charger	Yes	Size	363 x 331 x 96 mm
Devices per loop	226	Weight (without batteries)	4,5 Kg
Batteries Fuse	4 A	Standard	EN 54 parts 2 and 4
IP Protection	IP 30	S1 Sounder fuse	1,85 A autoreset
		30V Output fuse	0,75 A autoreset



# COMPACT LYON

## Addressable algorithmic control panel



REMOTE OPTION



The algorithmic addressable Control Panel Compact Lyon is EN 54-2 and EN 54-4 standard certified according to the latest CE Directives/Regulation.

The Compact Lyon panel does the same functions that Lyon Remote Control Panel, being fully compatible with it from the point of view of installation (cabling, analogue detectors, manual call points, modules and analogue sounders, etc.).

It is particularly interesting in medium-size installations, traditionally designed for conventional systems, allowing using an addressable system with all its functionality and advantage.

In case the installation should be extended, the Compact Lyon Control Panel has the control panels network function, whereby control panels can be connected together, also showing the information of the control panels connected to a repeater, besides allows an additional functionality of operation.

### Features:

- Control panel configurable with 1 or 2 loops.
- Loop capability 99 points.
- All the points are supervised by the control panel, except the loop isolator KABY.
- Capacity up to 16 relays per loop, 32 totally.
- Can hold up to 99 zones per panel.
- Registry with capacity of 6601 events with date and time.
- Relay configuration with activation of 1, 2 or 3 alarm detectors.
- Relay activation auto-configuration function.
- Allows the configuration of visual and/or sound devices of the detector bases as loop powered relays.
- Delay of supervised sounder output programmable between 0 to 10 minutes, identified as S1.
- Alarm output as free voltage relay not supervised, identified as ALARM.
- Fault output, delayed and supervised, identified as FAULT.
- Allowed to connect addressable sounders in the loop.
- Evacuation push-button.
- Backlit LCD display with 4 lines and 40 characters.
- Incorporates multiple languages by default (Spanish, English, French, Portuguese, etc).
- Configurable with the I-Link software.
- Access to the control panel keyboard introducing a numeric code.
- Allows connection of up to 15 repeaters and/or 15 control panels in network.
- Cofem Remote (on specific request).
- CRI functionality on demand.
- Size: 363 x 331 x 96 mm.
- Certified according to EN 54-2 and EN 54-4 and EN 54-4 and CE mark according to the European Regulation of Construction Products (UE) N°305/2011.

### TECHNICAL FEATURES

<i>Input Voltage</i>	110/230Vac 50/60Hz	<i>Maximum current per loop</i>	250 mA / 24 to 36V/DC
<i>Output Voltage</i>	24V Nominal	<i>Communications port</i>	USB 2.0/1.1 type B & RS485
<i>Maximum Consumption</i>	70 VA to 230V/AC	<i>Environmental conditions</i>	-10°C+50°C 20%-95% RH
<i>Batteries charger</i>	Yes	<i>Size</i>	363 x 331 x 96 mm
<i>Devices per loop</i>	99	<i>Weight (without batteries)</i>	4,5 Kg
<i>Batteries Fuse</i>	4 A	<i>Standard</i>	EN 54 parts 2 and 4
<i>IP Protection</i>	IP 30	<i>S1 Sounder Fuse</i>	1,85 A auto reset
		<i>30V Fuse Output</i>	0,75 A auto reset



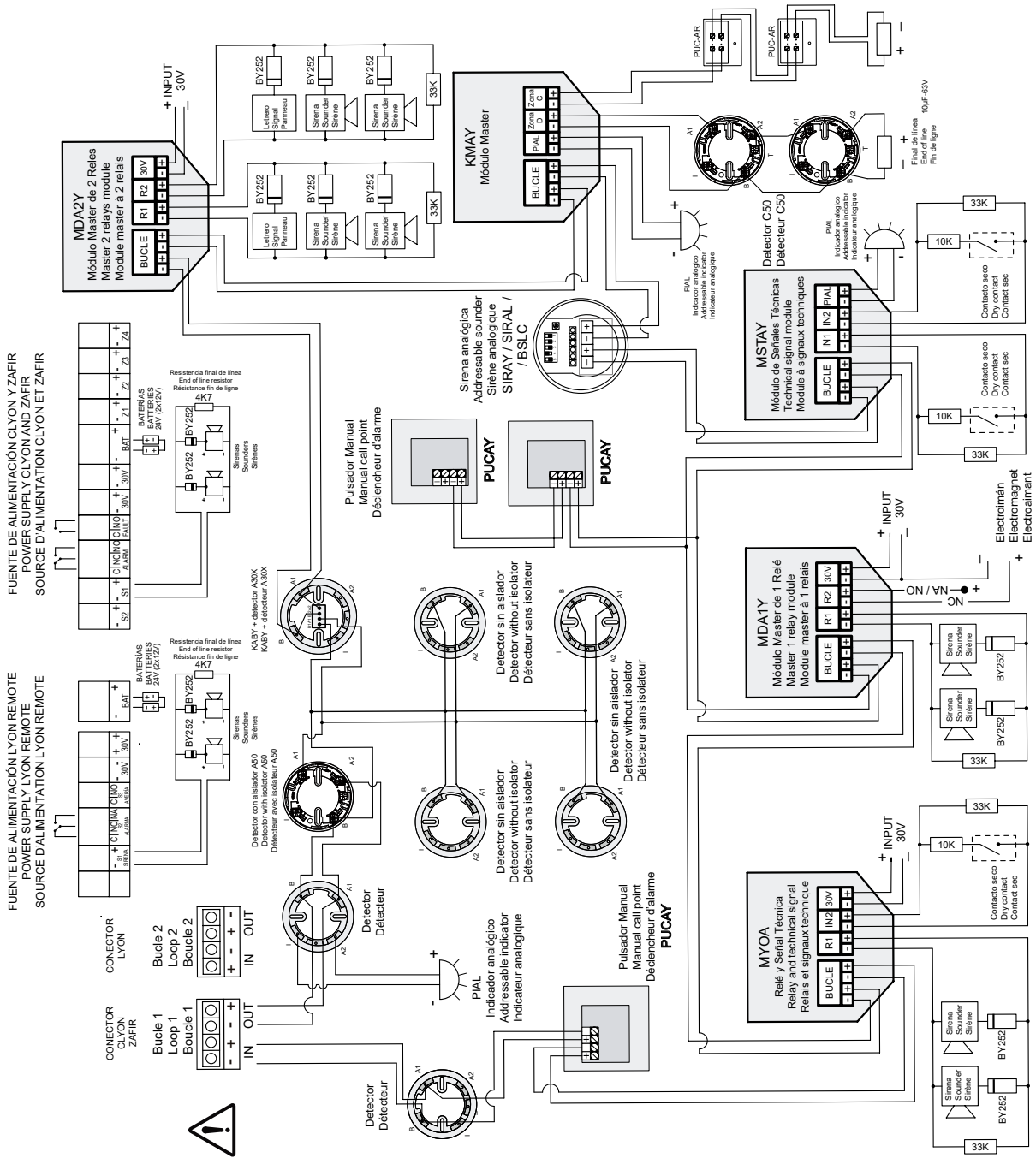

NOTE: Diagram indicates the installation of diodes in sounders. If these sounders have diode incorporated, it is not necessary to add it.

General wiring diagram Lyon Remote, Zafir y C-Lyon



## I-LINK

### Management software



I-LINK is a configuration and monitoring software for the Cofem algorithmic-addressable control panels. The I-LINK software is designed to perform two functions:

#### Configuration of the control panel:

With the software (in its basic version), the system's operating parameters can be configured by following a set of simple steps: the general activation parameters of the control panel, the definition of the points, the activation of the relays and the definition of the area listings and activation listings.

All this with functions that assist the user in simplifying the data entry procedures, such as the use of the Cofem Installer app (for smartphones and tablets), the display of the configuration settings in tree format, the possibility of copying and moving loops, of modifying the information directly on the tables of points, relays, etc.

Moreover, I-LINK allows for configuring the installation's video cameras and subsequently associating them in the extended version (ONLINE) to the detection elements.

#### ONLINE:

With the extended version of the software, I-LINK allows for ONLINE (real time) connection to the fire detection and alarm control panel, allowing the real-time display of the events, and also allowing for action to be taken (monitoring, cancelling, starting up, activating evacuation, etc.).

For an improved display, the installations blueprints can be entered in several formats (including Autocad) and the different detection elements can be placed on these blueprints. When an event occurs, the appropriate blueprint is opened, focusing on the event, enabling the user to zoom in, switch blueprints, see the sequence of events, etc. The installation's cameras can also be placed on the blueprints to relate them to the detection elements. Thus, when an event occurs, the related camera will be opened making it possible to view what is going on in that area of the installation. Also, at any time, you can click on any camera and view its images. On configuring the cameras, there is also the possibility of activating an image manager that will give us a warning in I-LINK ONLINE of the possible identification of fire.

By registering the installation in the Cofem Guard app (for smartphones, tablets or emails), I-LINK ONLINE will also send information of the events from the fire detection and alarm system to 5 users who will receive it in real time, depending on the connectivity/reception of these devices.

#### Features:

##### Basic Version (for programming the control panel):

- Allows for easy programming of the control panel from a PC.
- Allows for simple management of the configurations of all the Lyon Remote, Zafir and Compact Lyon installations.
- Loads the information on the installation's points from the Cofem Installer app.
- Configuration of the installation's video cameras.

##### Extended Version (for ONLINE management):

- Allows for ONLINE management of the control panel, offering many control possibilities.
- Displaying events on the installation's blueprints.
- Displaying of the video cameras of the fire detection events associated to the installation.
- Using RS232/485 converters, it allows for distances of up to 1200 m between the PC and the control panel.
- Allows for using wiring and the TCP/IP protocol in the installation.
- Possibility of managing up to 35 control panels simultaneously in a single installation.

NOTE: The functions offered in the product will depend on its version.

There are 4 software licences: ILINKLRM, for Lyon Remote control panels, ILINKZFR, for Zafir control panels, ILINKCTL, for Compact Lyon control panels, and ILINKONLINE, for use in any Cofem addressable control panel.





Lyon Remote connection diagram

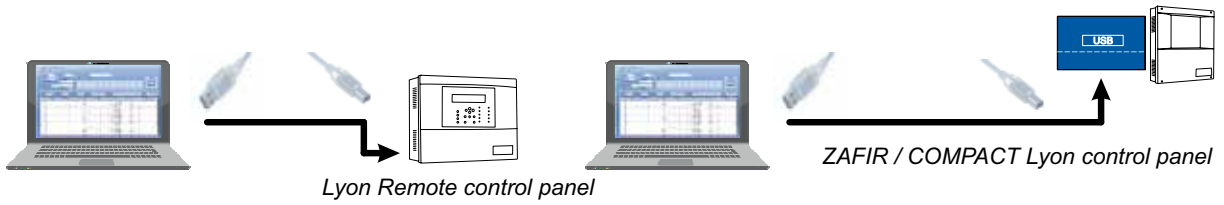

Connection 1 for control panel by RS485 or TCP/IP protocol (extended version)

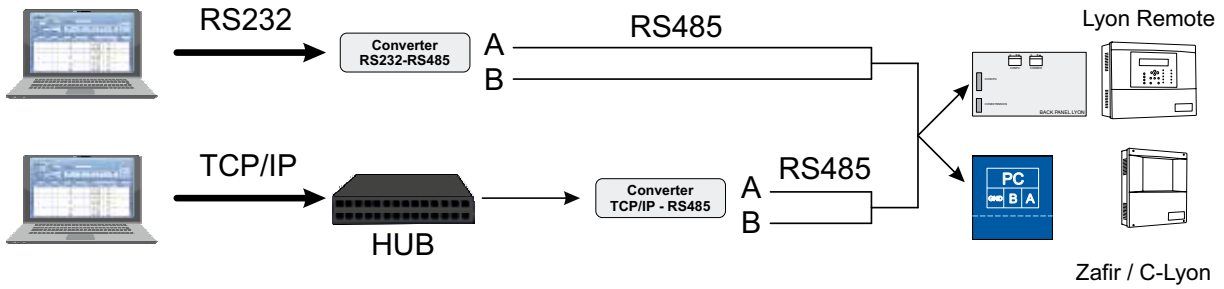

Example of connection network and with I-link

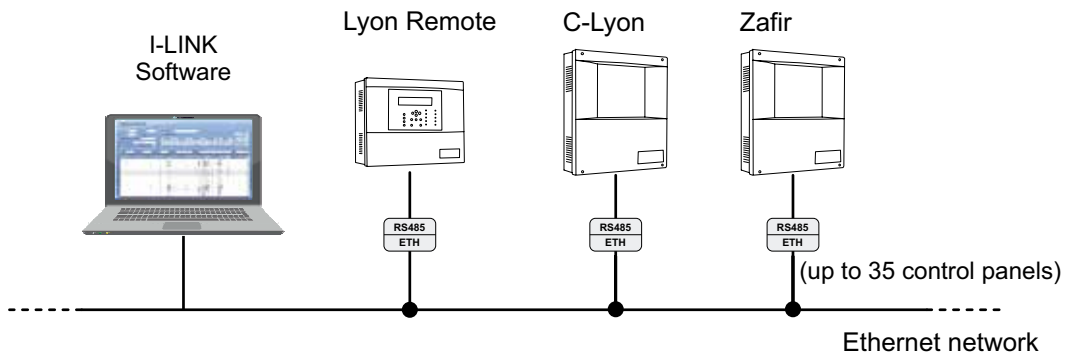
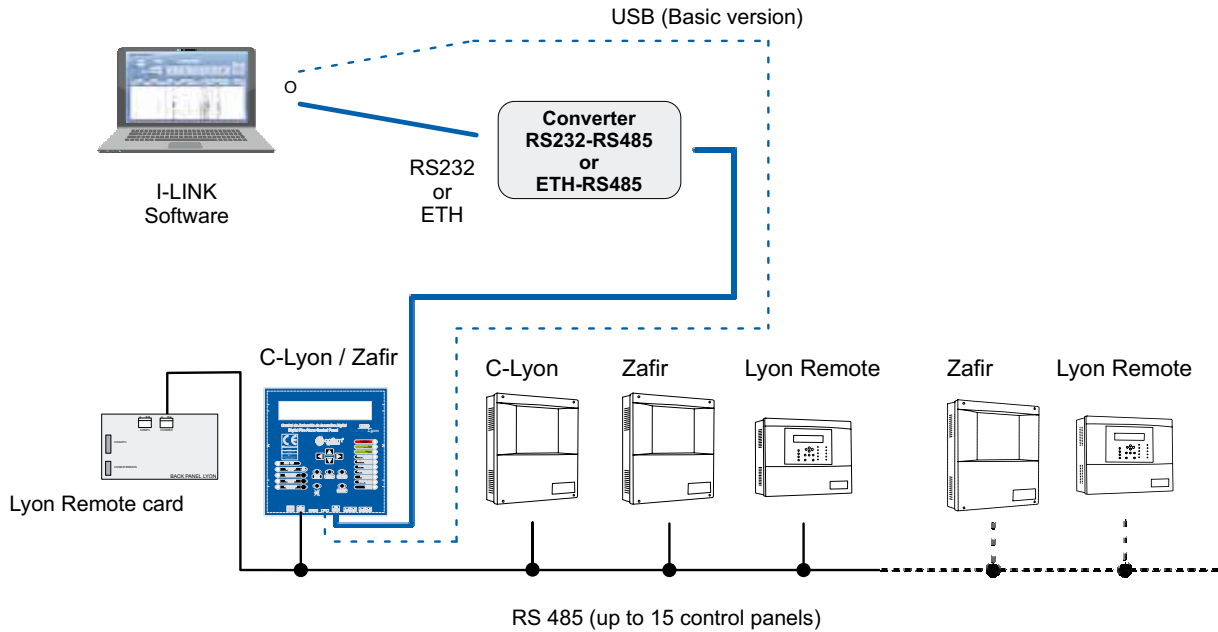



# APP'S

## Android apps



### COFEM INSTALLER

Effortless installation, thus preventing errors and saving time

Following Cofem's philosophy based on the simplicity and reliability of its systems, the "COFEM Installers" app has been created, with the purpose of gathering the installation data required for the quick and easy configuration of the algorithmic addressable fire detection and alarm control panels, in three steps:

- 1- Open the application.
- 2- Create a new installation.
- 3- Scan the QR codes of the components (detectors, call points, etc.)

With this application you can carry all the information around with you without needing to make notes on pieces of paper, also avoiding any possible reading and writing errors. The information on the installations can also be sent or received by any means available on the phone/tablet to configure the installation's settings with the EasyCoNET / I-Link programme.





# ZYR

## Algorithmic repeater control panel



The LYON REMOTE / ZAFIR / COMPACT Lyon control panel allows to connect up to 15 repeaters, using a 4 wires of 1,5 mm<sup>2</sup> connection (two for supply and two for communication for RS485 line). The two wires of the RS485 line will be connected from the control panel to the corresponding repeaters. The repeater wiring is realized like the figure attached.

From 30 V output of the control panel power supply is allowed up to 3 repeaters. For C-Lyon and Zafir control panels is allowed supply 1 repeater. The rest of repeaters should be connected from the 30 V output of an external power supply.

The wiring of repeaters, communication and power wires, will be realized with twisted and shielded halogen-free of 2x1,5 mm<sup>2</sup> wire, maximum length up to 1200 m.

In the end of the line should be connected a 120 Ω resistance, in the back panel of the last repeater.

### TECHNICAL FEATURES

Supply	30 V
Standby consumption	150 mA
Humidity	20 - 95% RH
Temperature	-10°C +50°C
Dimensions	283 x 240 x 35 mm
Weight (without batteries)	2,4 kg
IP protection	IP 30

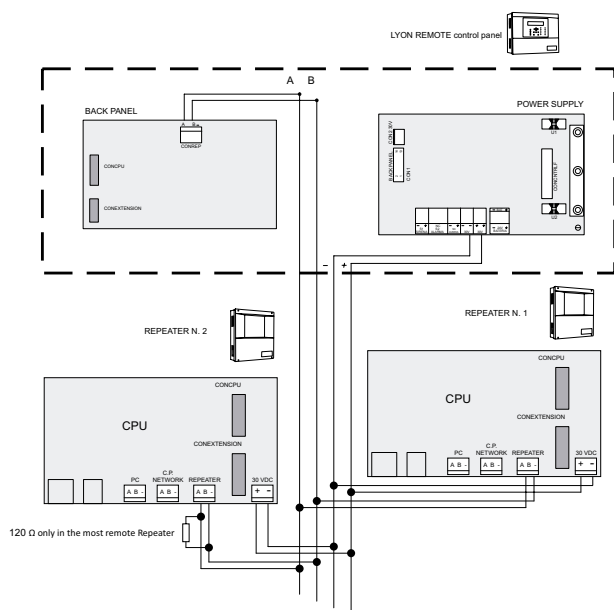

Lyon Remote control panel connection diagram

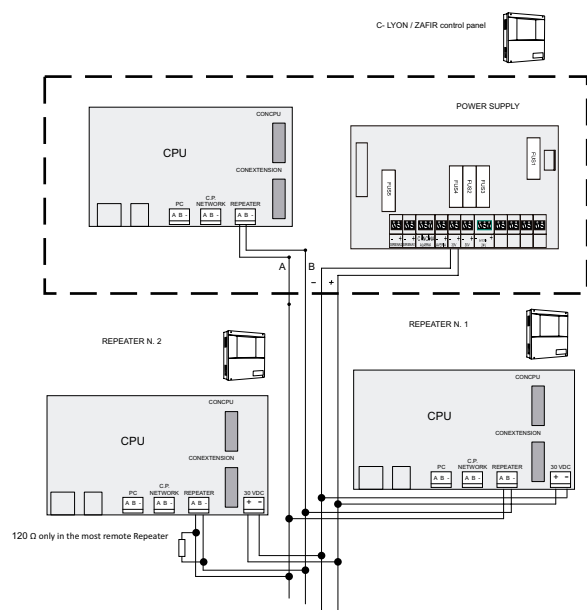

Zafir and Compact Lyon control panel connection diagram



# MCCRA

## Alarm receiving center addressable connection module



Addressable module for connecting with alarm receiving center.

EN 54-21 certified card that allows connection of the C-Lyon, Zafir or Lyon addressable control panel with an Alarm Receiving Center (ARC).

The following factory options are available including the control panel, its special communication software with the MCCRA card and the MCCRA card.

- CLYON01BCRI  
- CLYON02BCRI

- ZAFRI01BCRI  
- ZAFIR02BCRI

- LYONRM01CRI  
- LYONRM02CRI  
- LYONRM03CRI  
- LYONRM04CRI

\* Ask for configurations with a higher number of loops.

In the case of spare parts or the need to add this ARC connection functionality to an already installed addressable control panels, the MCCRA Reference includes the card and the control panel communication software update with this card (in versions compatible with this functionality).

Features:

- Certified EN 54-21
- Communication with ContactID protocol.
- GPRS and ethernet connection (selectable).
- Notification to the ARC of selected and scheduled events.
- User notification via SMS, e-mail or customised mobile application.
- Software programming on PC via PC port or remote connection.
- Remote access and control of control panel status.



# A50SHCOI



## Addressable multisensor with isolator



Addressable multisensor with isolator detector

The A50 family of detectors are based on a new refined aesthetic that integrates the latest electronic technology with new, more efficient detection algorithms and a three-dimensional design that makes it more robust against environmental dirt.

The A50 family allows multiple combinations between smoke and heat detection, CO sensor and short-circuit isolator with UL certification.

The A50SHCOI model is a multi-sensor detector that has a short-circuit isolator and three different types of sensors: An smoke sensor, a heat sensor and a Carbon Monoxide (CO) sensor.

The use of the CO sensor is very valuable for the early detection of some types of fire, since the production of this gas is very common, especially in the initial phases of a fire. Its integration with the smoke sensor results in a compact detector that is very robust against false alarms.

To complete its features, a heat sensor with thermovelocimetric response is incorporated, reaching alarm status with a static temperature of 60°C in the case of slow fire developments.

Features:

- Smoke, Heat and CO sensor.
- With short circuit isolator.
- Low profile, total height less than 55 mm (including low base).
- Also available with high base for 20 mm tube.
- Possibility of connection to a remote action indicator.
- Easy connection.
- Bi-color red and yellow LED.
- Indication, by means of the red LED, of the communication with the control panel (single flashing), as well as of the alarm status (LED on).
- Indication, by means of the yellow led (single flash), of the activation of the short-circuit isolator or the lack of communication with the control panel.
- Signalling of the dirty state of the sensor on the control panel display (the sensor allows to differentiate between rapid signal increases due to alarm and small, slow and sustained increases due to the accumulation of dust and dirt).
- Smoke and CO sensor processing algorithm that drastically reduces incidents due to false alarms.
- Easy installation of head and base, interchangeable throughout the A50 family, and made of white heat-resistant ABS.
- UL certified according to Standard EN 54-5 class A2R, EN 54-7 and EN 54 17 with CE marking according to the European Regulation on Construction Products (EU) No. 305/2011.

### TECHNICAL FEATURES

Power supply	24 - 35V
Standby current	300 µA
Alarm current	2 mA
Activation signal	Red light
Remote indicator	Yes
Humidity	20 - 95% RH
Temperature operative	-10°C +50°C
Sensitivity	EN 54-7/EN 54-5 A2R
IP protection	IP 20
Co sensor lifetime	10 years

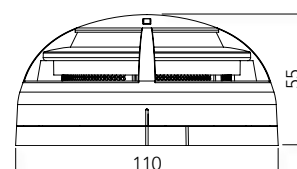
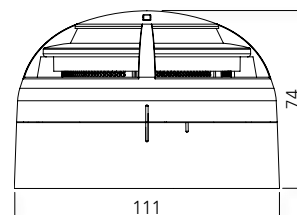



# A50SH



## Addressable smoke and heat sensor



### Addressable Smoke and Heat Detector

The A50 family of detectors are based on a new refined aesthetic that integrates the latest electronic technology with new, more efficient detection algorithms and a three-dimensional design that makes it more robust against environmental dirt.

The A50 family allows multiple combinations between smoke and heat detection, CO sensor and short-circuit isolator with UL certification.

The A50SH model is a detector that has two different types of sensors: An smoke sensor and heat sensor.

The smoke sensor is specially designed to detect the presence of combustion aerosols in a three-dimensional design that makes it more robust against dirt.

Regarding heat sensor, it allows the thermovelocimetric response of the detector, reaching the alarm status with a static temperature of 60°C in the case of slow fire developments.

### Features:

- Smoke and heat sensor.
- Low profile, total height less than 55 mm (including low base).
- Also available with high base for 20 mm tube.
- Possibility of connection to a remote action indicator.
- Easy connection, without polarity).
- Bi-color red and yellow LED.
- Indication, by means of the red LED, of the communication with the control panel (single flashing), as well as of the alarm status (LED on).
- Indication, by means of the yellow led (single flash), of the activation of the short-circuit isolator or the lack of communication with the control panel.
- Signalling of the dirty state of the sensor on the control panel display (the sensor allows to differentiate between rapid signal increases due to alarm and small, slow and sustained increases due to the accumulation of dust and dirt).
- Easy installation of head and base, interchangeable throughout the A50 family, and made of white heat-resistant ABS.
- UL certified according to Standard EN 54-5 class A2R and EN 54-7 with CE marking according to the European Regulation on Construction Products (EU) No. 305/2011.

### TECHNICAL FEATURES

Power supply	24 - 35V
Standby current	200 µA
Alarm current	2 mA
Activation signal	Red light
Remote indicator	Yes
Humidity	20 - 95% RH
Temperature operative	-10°C +50°C
Stockage temperature	-10°C +55°C
Sensitivity	EN 54-7/EN 54-5 category A2R
IP protection	IP 20

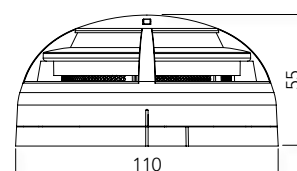
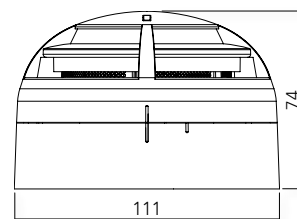



# A50SHI



## Addressable smoke and heat sensor with isolator



Addressable Smoke and Heat Detector

The A50 family of detectors are based on a new refined aesthetic that integrates the latest electronic technology with new, more efficient detection algorithms and a three-dimensional design that makes it more robust against environmental dirt.

The A50 family allows multiple combinations between smoke and heat detection, CO sensor and short-circuit isolator with UL certification.

The A50SHI model is a detector that has two different types of sensors: An smoke sensor and heat sensor. The A50SHI model incorporates a short circuit isolator.

The smoke sensor is specially designed to detect the presence of combustion aerosols in a three-dimensional design that makes it more robust against dirt.

Regarding heat sensor, it allows the thermovelocimetric response of the detector, reaching the alarm status with a static temperature of 60°C in the case of slow fire developments.

Features:

- Smoke and heat sensor.
- Short-circuit isolator incorporated.
- Low profile, total height less than 55 mm (including low base).
- Also available with high base for 20 mm tube.
- Possibility of connection to a remote action indicator.
- Easy connection.
- Bi-color red and yellow LED.
- Indication, by means of the red LED, of the communication with the control panel (single flashing), as well as of the alarm status (LED on).
- Indication, by means of the yellow led (single flash), of the activation of the short-circuit isolator or the lack of communication with the control panel.
- Signalling of the dirty state of the sensor on the control panel display (the sensor allows to differentiate between rapid signal increases due to alarm and small, slow and sustained increases due to the accumulation of dust and dirt).
- Easy installation of head and base, interchangeable throughout the A50 family, and made of white heat-resistant ABS.
- UL certified according to Standard EN 54-5 class A2R, EN 54-7 and EN 54-17 with CE marking according to the European Regulation on Construction Products (EU) No. 305/2011.

### TECHNICAL FEATURES

Power supply	24 - 35V
Standby current	300 µA
Alarm current	2 mA
Activation signal	Red light
Remote indicator	Yes
Humidity	20 - 95% RH
Temperature operative	-10°C +50°C
Stockage temperature	-10°C +55°C
Sensitivity	EN 54-7/EN 54-5 category A2R
IP protection	IP 20

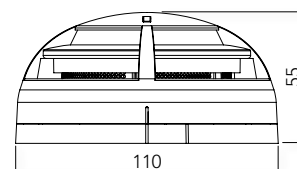
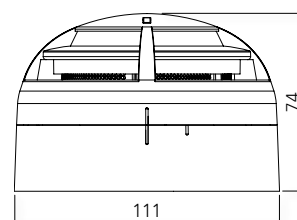



# A50S

## Addressable smoke sensor



### Addressable Smoke Detector

The A50 family of detectors are based on a new refined aesthetic that integrates the latest electronic technology with new, more efficient detection algorithms and a three-dimensional design that makes it more robust against environmental dirt.

The A50 family allows multiple combinations between smoke and heat detection, CO sensor and short-circuit isolator with UL certification.

The A50S model is a detector that has a smoke sensor.

The smoke sensor is specially designed to detect the presence of combustion aerosols in a three-dimensional design that makes it more robust against dirt.

### Features:

- Smoke sensor.
- Low profile, total height less than 42 mm (including low base).
- Also available with high base for 20 mm tube.
- Possibility of connection to a remote action indicator.
- Easy connection, without polarity.
- Bi-color red and yellow LED.
- Indication, by means of the red LED, of the communication with the control panel (single flashing), as well as of the alarm status (LED on).
- Indication, by means of the yellow led (single flash), of the activation of the short-circuit isolator or the lack of communication with the control panel.
- Signalling of the dirty state of the sensor on the control panel display (the sensor allows to differentiate between rapid signal increases due to alarm and small, slow and sustained increases due to the accumulation of dust and dirt).
- Easy installation head and base, interchangeable throughout the A50 family, and made of white heat-resistant ABS.
- UL certificate according to EN 54-7 Standard with CE marking according to the European Regulation on Construction Products (EU) No. 305/2011.

### TECHNICAL FEATURES

Power supply	24 - 35V
Standby current	200 µA
Alarm current	2 mA
Activation signal	Red light
Remote indicator	Yes
Humidity	20 - 95% RH
Temperature operative	-10°C +50°C
Stockage temperature	-10°C +55°C
Sensitivity	EN 54-7
IP protection	IP 20

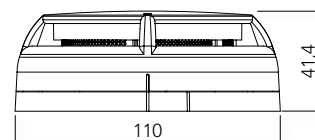
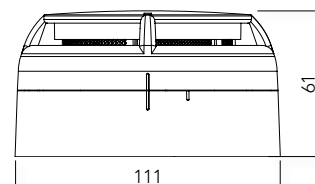





# A50SI



## Addressable smoke sensor with isolator



Addressable Smoke Detector with isolator.

The A50 family of detectors are based on a new refined aesthetic that integrates the latest electronic technology with new, more efficient detection algorithms and a three-dimensional design that makes it more robust against environmental dirt.

The A50 family allows multiple combinations between smoke and heat detection, CO sensor and short-circuit isolator with UL certification.

The A50SI model is a detector that has a smoke sensor. The A50SI model incorporates a short-circuit isolator.

The smoke sensor is specially designed to detect the presence of combustion aerosols in a three-dimensional design that makes it more robust against dirt.

Features:

- Smoke sensor.
- Short-circuit isolator incorporated.
- Low profile, total height less than 42 mm (including low base).
- Also available with high base for 20 mm tube.
- Possibility of connection to a remote action indicator.
- Easy connection (and A50S without polarity).
- Bi-color red and yellow LED.
- Indication, by means of the red LED, of the communication with the control panel (single flashing), as well as of the alarm status (LED on).
- Indication, by means of the yellow led (single flash), of the activation of the short-circuit isolator or the lack of communication with the control panel.
- Signalling of the dirty state of the sensor on the control panel display (the sensor allows to differentiate between rapid signal increases due to alarm and small, slow and sustained increases due to the accumulation of dust and dirt).
- Easy installation head and base, interchangeable throughout the A50 family, and made of white heat-resistant ABS.
- UL certificate according to EN 54-7 and EN 54-17 Standard with CE marking according to the European Regulation on Construction Products (EU) No. 305/2011.

### TECHNICAL FEATURES

Power supply	24 - 35V
Standby current	300 µA
Alarm current	2 mA
Activation signal	Red light
Remote indicator	Yes
Humidity	20 - 95% RH
Temperature operative	-10°C +50°C
Stockage temperature	-10°C +55°C
Sensitivity	EN 54-7
IP protection	IP 20

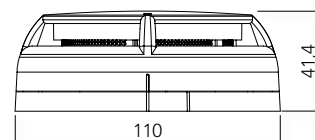
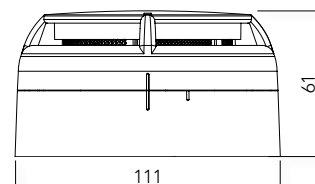



# A50H

## Addressable heat sensor



### Addressable Heat Sensor

The A50 family of detectors are based on a new refined aesthetic that integrates the latest electronic technology with new, more efficient detection algorithms and a three-dimensional design that makes it more robust against environmental dirt.

The A50 family allows multiple combinations between smoke and heat detection, CO sensor and short-circuit isolator with UL certification.

The A50H model is a detector that has a heat sensor.

The heat sensor has thermovelocimetric behaviour, reaching alarm status with a static temperature of 60°C in the case of slow fire developments.

### Features:

- Heat sensor.
- Low profile, total height less than 42 mm (including low base).
- Also available with high base for 20 mm tube.
- Possibility of connection to a remote action indicator.
- Easy connection (and A50S without polarity).
- Bi-color red and yellow LED.
- Indication, by means of the red LED, of the communication with the control panel (single flashing), as well as of the alarm status (LED on).
- Indication, by means of the yellow led (single flash), of the activation of the short-circuit isolator or the lack of communication with the control panel.
- Easy installation of head and base, interchangeable throughout the A50 family, and made of white heat-resistant ABS.
- UL certificate according to Standard EN 54-5 class A2R with CE marking according to the European Regulation on Construction Products (EU) No. 305/2011.

### TECHNICAL FEATURES

Power supply	24 - 35V
Standby current	200 $\mu$ A
Alarm current	2 mA
Activation signal	Red light
Remote indicator	Yes
Humidity	20 - 95% RH
Temperature operative	-10°C +50°C
Stockage temperature	-10°C +55°C
Sensitivity	EN 54-5 category A2R
IP protection	IP 20

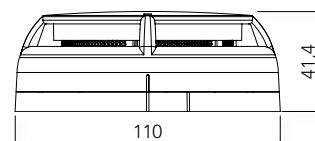
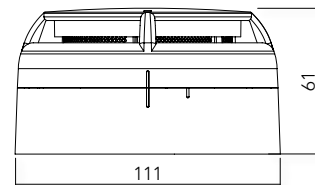

# A50HI



## Addressable heat sensor with isolator



### Addressable Heat Sensor with isolator

The A50 family of detectors are based on a new refined aesthetic that integrates the latest electronic technology with new, more efficient detection algorithms and a three-dimensional design that makes it more robust against environmental dirt.

The A50 family allows multiple combinations between smoke and heat detection, CO sensor and short-circuit isolator with UL certification.

The A50HI model is a detector that has a heat sensor. It also incorporates a short circuit isolator.

The heat sensor has thermovelocimetric behaviour, reaching alarm status with a static temperature of 60°C in the case of slow fire developments.

### Features:

- Heat sensor.
- Short-circuit isolator incorporated.
- Low profile, total height less than 42 mm (including low base).
- Also available with high base for 20 mm tube.
- Possibility of connection to a remote action indicator.
- Easy connection (and A50S without polarity).
- Bi-color red and yellow LED.
- Indication, by means of the red LED, of the communication with the control panel (single flashing), as well as of the alarm status (LED on).
- Indication, by means of the yellow led (single flash), of the activation of the short-circuit isolator or the lack of communication with the control panel.
- Easy installation of head and base, interchangeable throughout the A50 family, and made of white heat-resistant ABS.
- UL certificate according to Standard EN 54-5 class A2R and EN 54-17 with CE marking according to the European Regulation on Construction Products (EU) No. 305/2011.

### TECHNICAL FEATURES

Power supply	24 - 35V
Standby current	300 µA
Alarm current	2 mA
Activation signal	Red light
Remote indicator	Yes
Humidity	20 - 95% RH
Temperature operative	-10°C +50°C
Stockage temperature	-10°C +55°C
Sensitivity	EN 54-5 category A2R
IP protection	IP 20

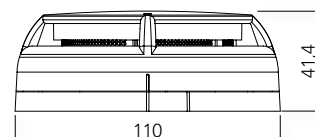
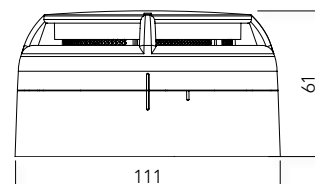



# A30XTA

## Algorithmic addressable heat sensor



Algorithmic addressable heat sensor for fire detection.

The A30XTA sensor is based on the physical properties of a NTC. The variation of the electrical features of the NTC thermistor due to variation of room temperature makes it suitable for a heat sensor.

The A30XTA is capable of registering absolute temperatures (heat sensor) but also temperature rises (rise of heat rate sensor).

The heat rate function allows detect a fire in the first phases of its growth. If it is very slow, the sensor is activated when temperature reaches 60°C.

Features:

- Low section, total height less than 45 mm (including the base).
- Available with high base for electrical conduit of 20 mm.
- Alarm with two red LED, which makes easier the identification from any direction (360°).
- Possibility to connect a remote action indicator.
- Easy connection, without polarity.
- A single flash of LED indicators shows communication with the control panel, and alarm status with LED on.
- Detector and base with easy installation, interchangeable with the entire of range A30X, and manufactured in white heat-resistant ABS.
- According to EN 54 part 5 class A2R (sensors with heat rise function), and CE mark according to the European Regulation of Construction Products (UE) N°305/2011.

### TECHNICAL FEATURES

Power Supply	24 - 35V without polarity
Standby Current	1 mA
Alarm Current	5 mA
Activation Signal	Two Red LED ( 360° visibility)
Remote Indicator Output	Yes
Humidity	20 - 95% RH
Temperature	-10°C +50°C
Sensitivity	According to EN 54-5 Class A2R
IP Protection	IP 20
Coverage area	56m <sup>2</sup> (subject to local regulation)

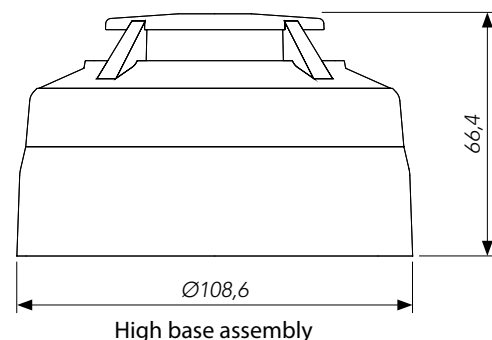

High base assembly



Other colors on request

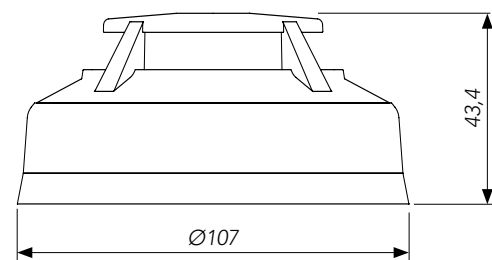

Low base assembly



# A30XHA A30XHAS



## Algorithmic addressable smoke optical sensor

Algorithmic addressable optical smoke sensor for fire detection.

The optical smoke sensor A30XHA / A30XHAS is based on the Tyndall effect (light refraction in a dark chamber) created in an optical chamber.

The variation of the electrical features of the chamber in the presence of combustion aerosols makes it suitable for smoke sensing.

The sensor A30XHA (optical-heat sensor) also has a static heat element that sets it into alarm status when temperature reaches 60°C.

Features:

- Low section, total height less than 53,4 mm (including the base).
- Available with high base for electrical conduit of 20 mm.
- Alarm with two red LED, which makes easier the identification from any direction (360°).
- Possibility to connect a remote action indicator.
- Easy connection, without polarity.
- A single flash of LED indicators shows communication with the control panel, and alarm status with LED on.
- Indication of contamination status of the sensor in the control panel display (the sensor discriminates between fast alarm signal and slow and sustained small increases due to the accumulation of dust and dirt).
- Detector and base with easy installation, interchangeable with the entire of range A30X, and manufactured in white heat-resistant ABS.
- According to EN 54-7 Standard, and CE mark according to the European Regulation of Construction Products (UE) N°305/2011.

### TECHNICAL FEATURES

Power Supply	24 - 35V without polarity
Standby Current	1 mA
Alarm Current	5 mA
Activation Signal	Two Red LED (360° visibility)
Remote Indicator Output	Yes
Humidity	20 - 95% RH
Temperature	-10°C +50°C
Sensitivity	According to EN 54-7
IP Protection A30XHA	IP 20
IP Protection A30XHAS	IP 40
Coverage area	112m <sup>2</sup> (subject to local regulation)

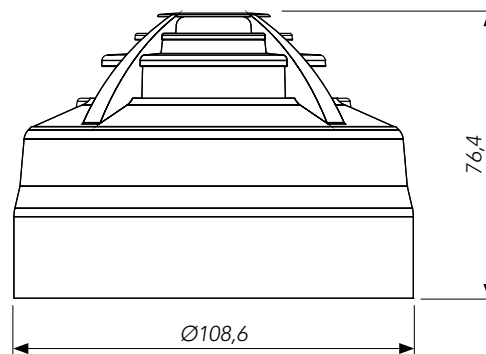

High base assembly

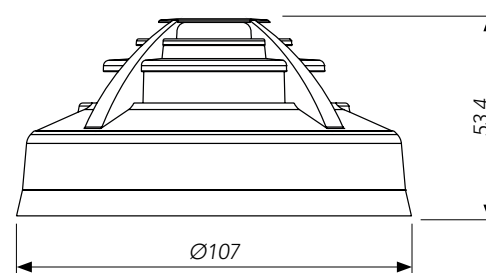

Low base assembly



Other colors on request



# A30XHTCO

## Algorithmic addressable multisensor



Algorithmic addressable multisensor for fire detection.

The A30XHTCO has three different types of sensors: one optical smoke sensor, one heat sensor and one carbon monoxide sensor (CO).

The use of the CO sensor is very valuable for the early detection for some types of fire.

As well, the integration with the optical smoke detector inside its algorithm of dynamic processing, give us, as main results, a compact detector very robust facing the false alarms

For complete its benefits, the sensor also has a heat element sets it alarm status when temperature reaches 60°C.

Features:

- Low section, total height less than 53,4 mm (including the base).
- Available with high base for electrical conduit of 20 mm.
- Alarm with two red LED, which makes easier the identification from any direction (360°).
- Possibility to connect a remote action indicator.
- Easy connection, without polarity.
- A single flash of LED indicators shows communication with the control panel, and alarm status with LED on.
- Indication of contamination status of the sensor in the control panel display (the sensor discriminates between fast alarm signal and slow and sustained small increases due to the accumulation of dust and dirt).
- Dynamic processing algorithm that reduces drastically incidences due to false alarms.
- Detector and base with easy installation, interchangeable with the entire of range A30X, and manufactured in white heat-resistant ABS.
- According to EN 54-7 Standard, and CE mark according to the European Regulation of Construction Products (UE) N°305/2011.

### TECHNICAL FEATURES

Power Supply	24 - 35V without polarity
Standby Current	1 mA
Alarm Current	5 mA
Activation Signal	Two Red LED (360° visibility)
Remote Indicator Output	Yes
Humidity	20 - 95% RH
Temperature	-10°C +50°C
Sensitivity	According to EN 54-7
IP Protection	IP 40
Lifespan	10 years
Coverage area	112m <sup>2</sup> (subject to local regulation)

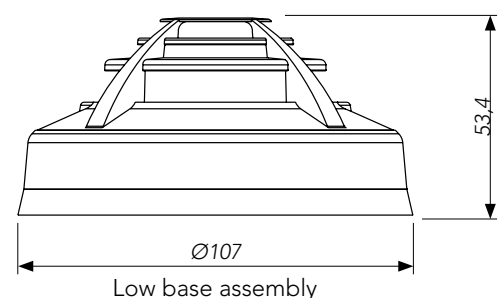
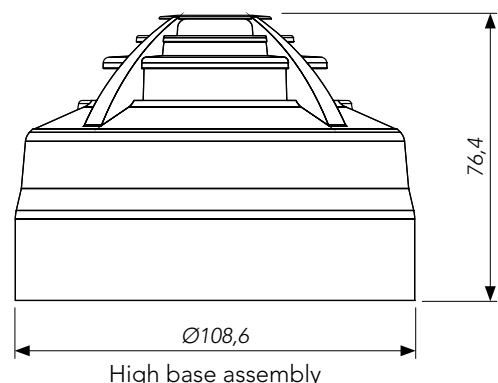

Other colors on request



# PUCAY

## Resettable manual call point



Resettable Manual Call Point (with short-circuit isolator) for algorithmic addressable detection systems.

It has a LED that lights up when the call point is manually triggered (alarm), as well as showing a yellow tab on the lower side of the activation face. A single flash shows communication with the control panel.

It is easy to reset through activation of the yellow button sited in the front face by means of a screwdriver.

Features:

- Easily resettable call point by pushing yellow button on the front side.
- Transparent protector cover to avoid accidental false alarms.
- Self-identified element in the fire detection algorithmic and addressable.
- Communication with the control panel is indicated by a single flash of the LED.
- Immediate visual recognition of alarm status by the permanent activation of the LED, and the trigger of the yellow tab on the lower side of the activation face.
- According to EN 54-11 Standard, and CE mark according to the European Regulation of Construction Products (UE) N°305/2011.

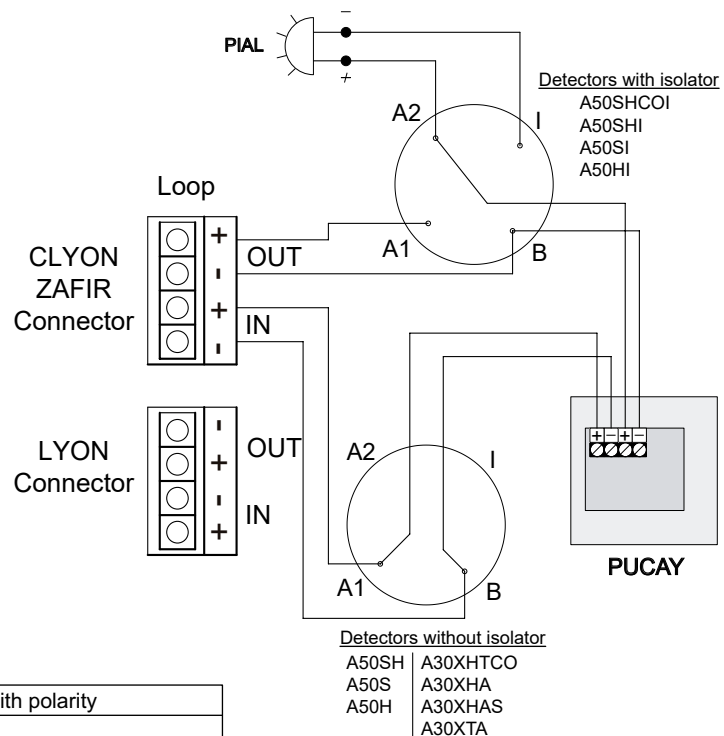
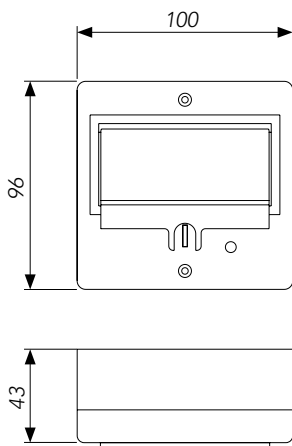

### TECHNICAL FEATURES

Power Supply	24 - 35V with polarity
Standby Current	1 mA
Alarm Current	5 mA
Activation Signal	Red Light
Remote Indicator Output	No
Humidity	20 - 95% RH
Temperature	-10°C +50°C
Standard	EN 54-11
IP Protection	IP 50

## SIRAY SIRAYL SIRAY+BSLC



### Addressable alarm sounders

The references SIRAY / SIRAYL / SIRAY + BSLC are made up of the following elements:

- SIRAY= Sounder + SIRAYC card
- SIRAYL= Sounder with light + SIRAYC card
- SIRAY+BSLC= Sounder + SIRAYC card + Base with light

SIRAYC card is a digital module microprocessed and addressable device (with short-circuit isolator) installed as another element inside the loop. The sounder is made of in ABS heat-resistant plastic red color.

Is a module with a single programming function in terms of the timing and combination of sensors that trigger it. This sounder is configured as a relay acting as sounder.

The variant SIRAYL and SIRAY+BSLC additionally emit light signals, where in addition, the SIRAY+BSLC makes it according to EN 54-23 (visual alarm device). The fact that specifically these sounders emitting light does not affect the programming of the control panel. For this reason, these devices are programmed in the control panel as if they were the reference SIRAY.

The standard configuration of the sound of the sounder is shown in the bottom figure according to EN 54-3 (acoustic device). The same figure shows the standard configuration of the light signal at the base of the sounder SIRAY+BSLC according to EN 54-23 (visual alarm device).

It is possible to change the tone and light signal selection, but this operation affects the power consumption of the sounder, and therefore, the consumption of the device points. It is possible to calculate the consumption with the calculation software of loop elements capacity.

Internal wiring and other microswitch positions must be unmodified selected by the manufacturer.

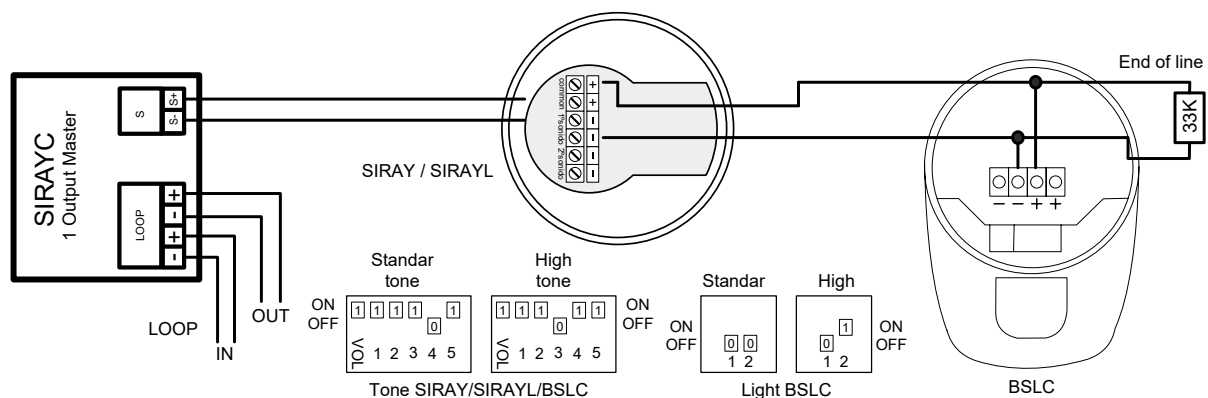

### TECHNICAL FEATURES

Power supply	24 - 35V with polarity	Standard	EN 54-3 / EN 54-23 (BSLC)
Standby current	3 mA		SIRAYC: EN54-17 and EN54-18
Alarm current	5 - 50 mA	IP protection	IP 65 (SIRAY+BSLC) and SIRAYL
Short-circuit isolator	Yes		IP 54 SIRAY
Operating temperature	-10°C + 55°C	Sound level	95 / 105 dB - 1m (SIRAY / SIRAYL)
Size	Ø95 x 91mm / Ø95 x 107 mm (SIRAYL) Ø95 x 95 (high) x 135 mm (SIRAY+BSLC)	Light level	w 2,4 - 2,3 / 7,5 m (BSLC)

Figure 2





# PIAL

## Remote indicator



Remote action indicator of fire algorithmic detection system.

The PIAL allows showing alarm status of algorithmic sensors.

Typical cases of use:

- Places where elements of the detection system are not visible, for example, inside false ceiling, in which the PIAL can be visibly situated on the lower part of the ceiling or near the wall.
- Reduced accessibility rooms or that is needed do a big inspection range for the identification of the element in alarm, for example in hotel rooms, where the PIAL can be situated above the door frame of each room, making very easy its identification.

Permanent activation of the red LED indicates alarm status.

It is an element easy to install, both for its electrical wiring and its fixation. Furthermore, can be adapted to the conduit boxes and switchgear.

Features:

- Alarm status can be identified in any perpendicular direction at its installation.
- Easy connection, with polarity.
- Can be adapted to the conduit boxes and switchgear.
- The red light is produced by two LEDs, increasing reliability against failure of any of them.
- Manufactured in heat-resistant ABS. Base and lid are white, red viewer.

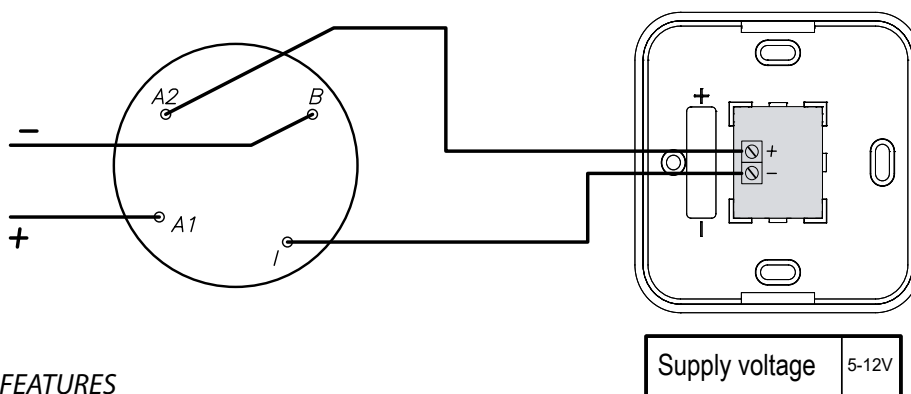

### TECHNICAL FEATURES

Supply	5 - 12 V/DC with polarity
Standby consumption	0 mA
Alarm consumption	5 mA
Activation signal	Red led
Humidity	20 - 95% RH
Temperature	-10°C +50°C
IP protection	IP 50



# KMAY

## Module to connect conventional devices



Microprocessed algorithmic addressable loop device (with short-circuit isolator)

This is a device that allows connecting conventional detectors and/or manual call point inside an algorithmic addressable fire detection system, performing the interface function between the algorithmic addressable detection system and the conventional one.

In the "Zona C" terminal, a maximum of 10 conventional call points can be installed. In the "Zona D" terminal, it is allowed 20 temperature detectors (A30XT, A30XV) or 15 elements between conventional smoke detectors (A30XH, A30XHS) and manual call points. Both terminals are monitored by an end of line capacitor, 10µF/63V. In this way, it is indicated an open line, crossed line, alarm detector or alarm manual call point status.

The red Led blinking indicates communication with the control panel, and if it remains lit it indicates the alarm status of a detector or a manual call point connected to this module.

This module has an output for activation of a remote indicator which will be activated when alarm status is reached. The Master Detection Module is a loop powered device.

The Master Detection Module is supplied in a rectangular, heat-resistant ABS box.

The module is certified according to EN 54-18 Standard, and CE mark according to the European Regulation of Construction Products (UE) N°305/2011.

### TECHNICAL FEATURES

Power Supply	24 - 35V with polarity
Standby Current	1 mA
Short-Circuit Isolator	Yes
Zone voltage	20V with polarity
Activation Signal	Red Light
Remote Indicator Output	Yes
Humidity	20 - 95% RH
Temperature	-10°C +50°C
Size	140,5 x 73 x 48mm
Standard	EN 54-18
IP Protection	IP 30

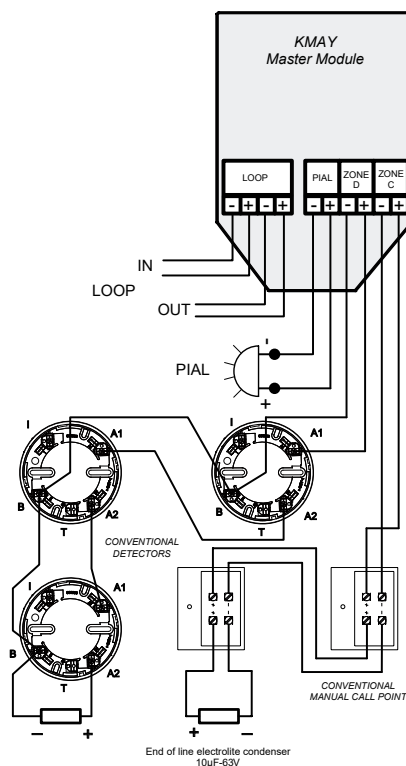



# MSTAY

## Technical signals module



Microprocessed algorithmic addressable loop device (with short-circuit isolator).

It has two inputs to distinguish between the open or close state of a dry contact connected in series with a 10 kΩ resistor. In quiescent condition, the contact has to be open, and in anomaly condition, the contact has to be closed. In the first input (marked with IN1), the closed contact is detected as an ALARM condition. In the second input (marked with IN2), the closed contact is detected as FAULT warning condition. It is possible to associate both inputs having an alarm and fault conditions information.

In the quiescent condition, the device supervises the electrical connection through a 33 kΩ resistor, which allows indication of open electrical connection or short circuit status.

It is usually used to inform about the status of other detection systems associated to Cofem systems, like flow sensors in the case of sprinkler installations, end of stroke for fire-resistant doors, elevators, or level of deposits, etc.

The red Led blinking indicates communication with the control panel, and if it remains lit it indicates the alarm status. The lit green LED indicates activation of one or both inputs.

This device has an output for connection to a remote action indicator, which is activated when in case of alarm status. The technical signals module is a loop powered device.

The device is supplied in a rectangular, heat-resistant ABS box.

The module is certified according to EN 54-18 Standard, and CE mark according to the European Regulation of Construction Products (UE) N°305/2011.

### TECHNICAL FEATURES

Power Supply	24 - 35V with polarity
Standby Current	1 mA
Short-Circuit Isolator	Yes
Supervision voltage	7V with reverse polarity
Remote Indicator Output	Yes
Activation signal	Green Light
Communication/Alarm Indicator	Red Light
Humidity	20 - 95% RH
Temperature	-10°C +50°C
Size	140,5 x 73 x 48 mm
Standard	EN 54-18
IP Protection	IP 30

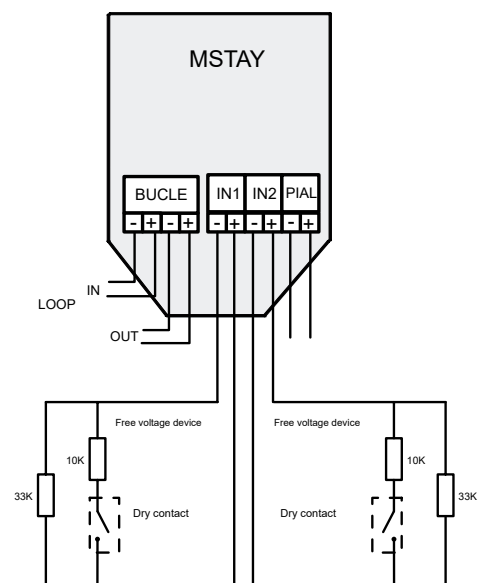



# MDA1Y

## 1 relay output module



Microprocessed algorithmic addressable loop device (with short-circuit isolator)

The module loop powered but it requires an auxiliary 30V supply power to provide the necessary energy to the devices controlled by the relays. It supervise the voltage presence in the auxiliary supply line of 30V and in the output of the supervised relays.

The module is protected by 0,9 A resettable fuse and each output is supervised by 0,5 A.

The red Led blinking indicates communication with the control panel, the lit green LED indicates the activation of one or both relays.

It is a module with simultaneous activation (with a single function) of two outputs relay , both in its type of application (siren, activation or pre-alarm), as well as in its timing and combination of sensors that activate them.

The R1 output relay is supervised by a final line resistance of 33 kΩ that indicate the state of opened line or short circuit. The R2 output relay operate as a dry contact NO and NC, not supervised, It is usually used to activate the fire-resistant doors electromagnets. The installation of an external power supply is recommended in case to use more than 10 electromagnets together.

The device is supplied in a rectangular heat-resistant ABS box.

The module is certified according to EN 54-18 Standard, and CE labelled according to the European Regulation of Construction Products (UE) N°305/2011.

### TECHNICAL FEATURES

Power Supply	24 - 35V with polarity
Standby Current	1 mA
Short-Circuit Isolator	Si
Relay supervision voltage	7V with reverse polarity
Relay output voltage	30V
Activation signal	Green Light
Communication Indicator	Red Light
Humidity	20 - 95% RH
Temperature	-10°C +50°C
Size	140,5 x 73 x 48 mm
Standard	EN 54-18
IP Protection	IP 30

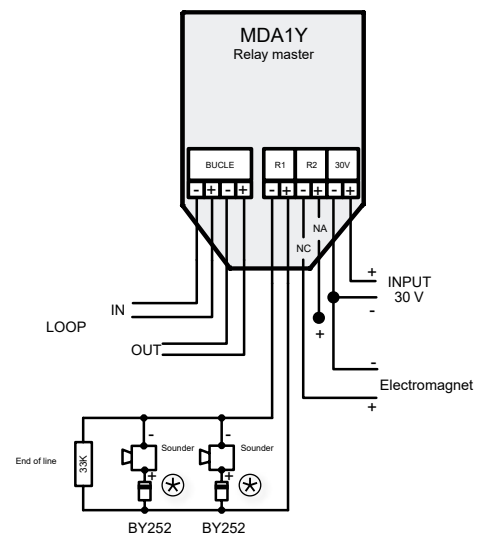

⊗ It depends on if the sounder has diode incorporated



# MDA2Y

## 2 relays supervised output module



Microprocessed algorithmic addressable loop device (with short-circuit isolator).

The module takes the power supply from the loop, but it requires an auxiliary 30 V supply to give the necessary energy to the devices controlled by the relays. It monitors the presence of voltage in the auxiliary supply line of 30V and in the output of the monitored relays.

The module is protected by 0,9 A resettable fuse and each monitored output by 0,5 A.

The flashing of the transparent red LED indicates communication with the control panel. Illumination of the green LED indicates the actuation of a relay.

It is a module with two relay outputs of independent activation (two functions), not only in their type of application (sounder, switches or crossed relay), but also in their timing and in the combination of sensors that activate them.

In the standby state, the MDA2Y monitors both external line by means of a 33 kΩ resistance, indicating the state of open line or crossed line.

The device is supplied in a rectangular heat-resistant ABS box.

The module is certified according to EN 54-18 Standard, and CE labelled according to the European Regulation of Construction Products (UE) N°305/2011.

### TECHNICAL FEATURES

Power Supply	24 - 35V with polarity
Standby Current	1 mA
Short-Circuit Isolator	Si
Relay supervision voltage	7V with reverse polarity
Relay output voltage	30V
Activation Signal	Green Light
Communication Indicator	Red Light
Humidity	20 - 95% RH
Temperature	-10°C +50°C
Size	140,5 x 73 x 48 mm
Standard	EN 54-18
IP Protection	IP 30

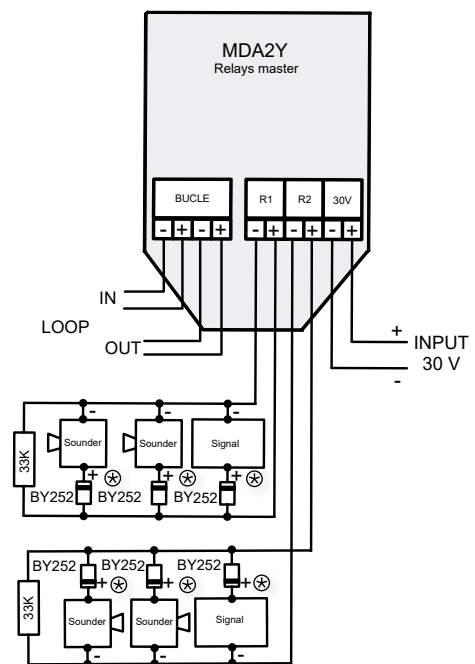

⊗ It depends on if the sounder has diode incorporated

# MYOA MYOAF



## Output input module

Microprocessed algorithmic addressable device (with short-circuit isolator) installed as another element inside the loop.

This module has one relay output fed by external 30V and one technical signal input to distinguish the open or closed state of a dry contact. The Module is protected by 0,9 A resettable fuse and the relay by 0,5 A.

This module is electrical fed through the loop connection, but it is required auxiliary 30V for feeding the equipment's connected to the relay output "R1". The relay is configured with only one function (sounder, switched or crossed relay), but also in its timing and in the combination of sensors that activate it. The module monitors the presence of voltage in the auxiliary supply line of 30V and in the output of the monitored relay. The voltage output of the relay is 30V.

The technical signal input has a 10 kΩ resistor connected in series with the dry contact. In quiescent condition, the contact has to be open, and in anomaly condition, the contact has to be closed. In the input (marked with IN2), the closed contact is detected as ALARM condition.

There is also the MYOAF version, which is identical to the MYOA, except that the closed contact is detected as a fault.

The MYOA supervises each external line (relay output and technical signal input) through a 33kΩ each one, which allows indication of open or closed electrical connection status.

The flashing of the transparent red LED indicates communication with the control panel, the fix light of red led indicates the alarm status of the input, and the illuminated green LED indicates the activation of the relay.

The Relay and Technical Signal Module is placed in a rectangular, head-resistant ABS box.

The module is certified according to EN 54-18 Standard, and labelled according to the European Regulation of Construction Products (UE) N°305/2011.

### TECHNICAL FEATURES

Power Supply	24 - 35V with polarity
Standby Current	1 mA
Short-Circuit Isolator	Yes
Supervision voltage	7V with reverse polarity
Remote Indicator Output	No
Activation signal	Green Light
Communication/Alarm Indicator	Red Light
Humidity	20 - 95% RH
Temperature	-10°C +50°C
Size	140,5 x 73 x 48 mm
Standard	EN 54-18
IP Protection	IP 30

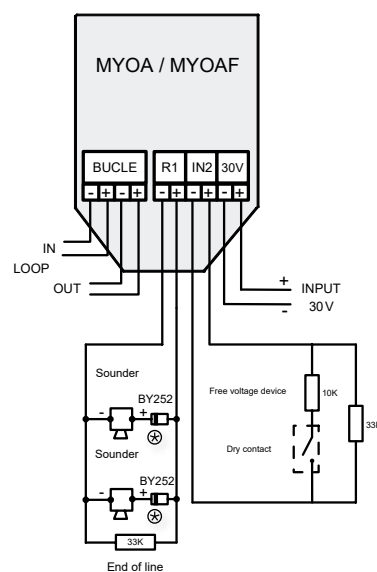

⊗ It depends on if the sounder has diode incorporated



# MDA2YLT

## 2-relay output module



Microprocessed and algorithmic-addressable module (with short-circuit insulator) which is installed as one more element in the loop.

The modules are powered by the loop connection, requiring no outside power. The blinking red transparent LED shows there is communication with the control panel. The fixed lit red transparent LED indicates that one or both relays have been triggered.

To order, rectangular boxes made of heat-resistant ABS are available.

This is a module with two relay outputs that are separately activated (two functions), independent timing, as well as a combination of sensors that activate them. The R1 and R2 outputs are voltage free C/ NC/ NA. Using this module, we can control fire doors and gates.

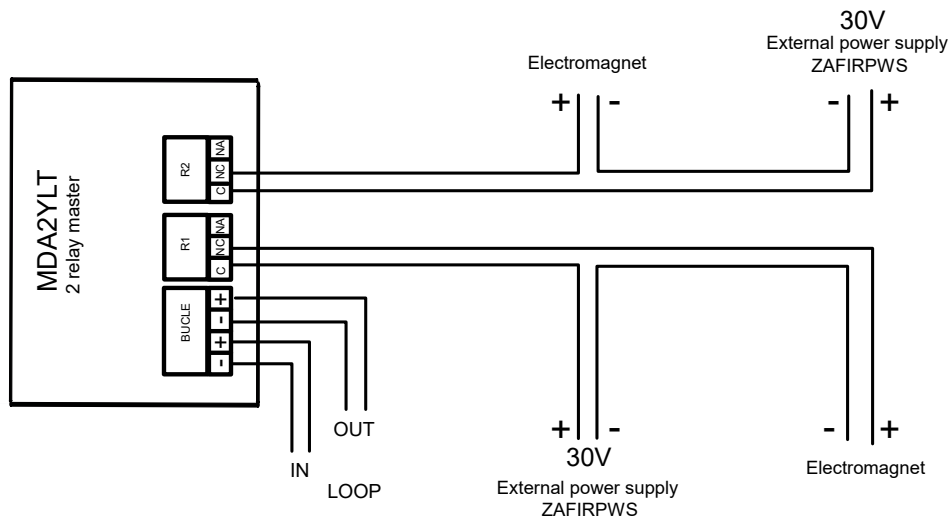

### TECHNICAL FEATURES

Power supply	24 - 35V with polarity
Standby Current	1 mA
Activated consumption	4 mA
Loop isolator	Yes
Maximum resistive load	5A / 250 VAC
Activation indicator	red led (fixed)
Communication indicator	red led (blinking)
Humidity	20 - 95% RH
Temperature	-10°C +50°C
Dimensions	159 x 118 x 72 mm
IP protection	IP 55

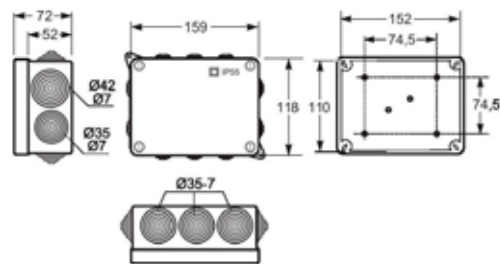

Assembly box dimensions



# KMAY32

**Module to connect**  
**32 detectors / 10 detectors**



Microprocessed and algorithmic-addressable module (with short-circuit insulator) which is installed as one more element in the loop.

This module allows the connection of conventional detectors and/or alarm call points in an algorithmic-addressable fire detection system, performing the interface function between an algorithmic-addressable control panel and a conventional system. Up to a maximum of 10 conventional alarm call points can be installed on the strip of "Area C". The "D Area" strip allows a maximum of 32 temperature detectors (A30XT, A30XV) or 32 components between smoke detectors (A30XH, A30XHS) and conventional alarm call points. Both strips supervise the line using a 4K7 end-of-line resistor. It thus indicates the status of the open line, crossed line, detector alarm or alarm call point alarm.

It has a microswitch for setting the area thresholds;

- Open line threshold (pin microswitch 1-2).
- Detector alarm triggered threshold (pin microswitch 3-4).
- Alarm call point triggered threshold (pin microswitch 5).

The blinking of the red transparent LED indicates communication with the control panel, and if it stays on in indicates the status of the alarm of a detector or of a alarm call point connected to that module.

This module has an output for the activation of a remote pilot, which is activated when it is in alarm state.

This module is powered by the loop connection and requires a 24V auxiliary power supply to power the areas, said voltage is supervised by the microcontroller.

Rectangular boxes made of heat-resistant ABS are available on order.

## TECHNICAL FEATURES

Loop power supply	24 - 35V with polarity
Auxiliary 24V power supply	20 - 30V
Standby consumption	1,5 mA
Shor-circuit isolator	Yes
Area voltage	22V with polarity
Remote indicator output	Yes
Activation indicator	red led (fixed)
Communication indicator	red led (blinking)
Humidity	20 - 95% RH
Temperature	-10°C +50°C
Dimensions	159 x 118 x 72 mm
IP protection	IP 55



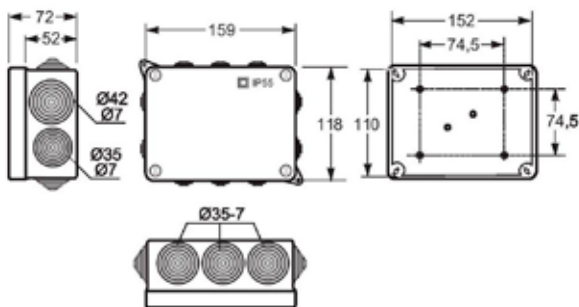
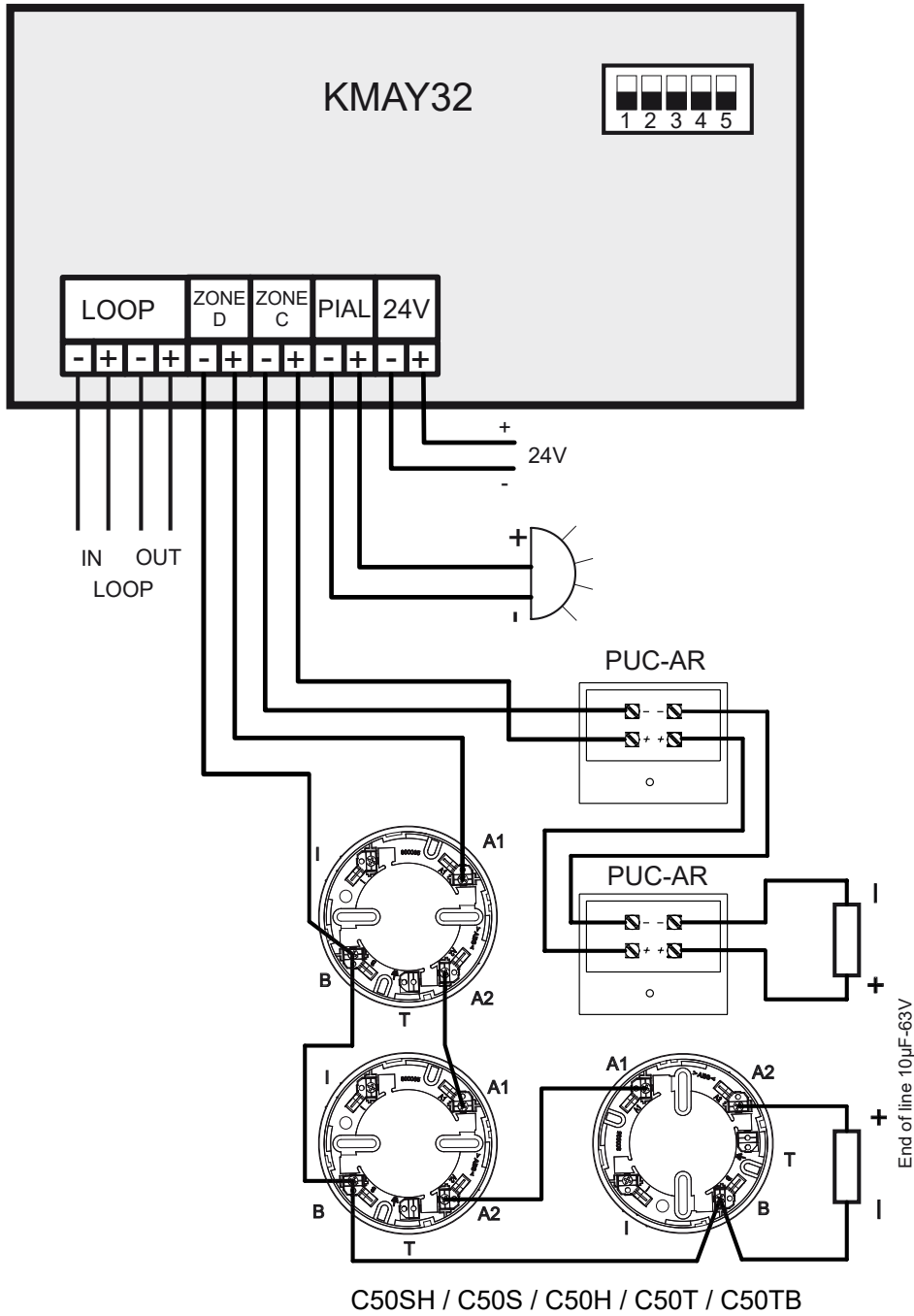

Assembly box dimensions



# MSTAY8

## Module with 8 inputs



Microprocessed and algorithmic-addressable module (with short-circuit insulator) which is installed as one more element in the loop.

It has eight inputs to monitor equipment external to the system.

It is typically applicable for signalling the status of other detection systems in which there could be a connection to flow sensors in the case of sprinkler installations, travel path end-stops in the case of fire doors, lifts, tank levels, pressure units, etc.

These inputs are configurable by microswitch in the following manner:

- Supervised (pin 1 microswitch set to ON); the outside line in supervised standby state by means of a 33KΩ resistor, indicating the status of the line or crossed line. Connecting a parallel 10kΩ resistor will activate the related input.
- Active by closed contact (pin 1 microswitch set to OFF and pin 3 microswitch set to OFF); the input in standby must be with the contacts open, in case of event the input contacts must be crossed. This will be the factory setting.
- Active by open contact (pin 1 microswitch set to OFF and pin 3 microswitch set to ON); the input in standby must be with the contacts crossed, in case of event the contacts must be opened.

Using pin 2 of the configuration microswitch we will select the type of event that the module will send to the control panel: ON Fault and OFF Alarm.

The configuration of the inputs is common to all of them.

The blinking of the transparent red LED indicates communication with the Lyon control panel and also if it stays lit it indicates the activation of one or several inputs. This module has an output for the activation of a remote pilot, which is activated when it is in alarm state. The Technical Signals module is powered by the connection to the loop.

Rectangular boxes made of heat-resistant ABS are available on order.

### TECHNICAL FEATURES

Power supply	24 - 35V with polarity
Supervision-free mode standby consumption	
Active by closed contact	2 mA
Active by open contact	5 mA
Supervised mode standby consumption	2,5 mA
Non supervision-free mode alarm consumption	
Active by closed contact	14 mA
Active by open contact	11 mA
Supervised mode alarm consumption	14 mA
Short-circuit isolator	Si
Supervision voltage	5 V with inverted polarity
Remote indicator output	Si
Activation indicator	red led (fixed)
Communication indicator	red led (blinking)
Humidity	20 - 95 % RH
Temperature	-10°C +50°C
Dimensions	159 x 118 x 72
IP protection	IP 55

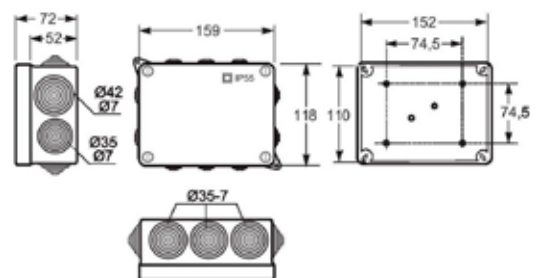

Assembly box dimensions





# A50ZSLDR A50ZSDDR



## Addressable alarm devices

Base for A50 algorithmic-addressable detectors with EN 54-23 certified visual alarm base and EN 54-3 sounder supplied directly from the loop.

There are 2 models available:

- A50ZSLDR: D50 base with sound and light base, addressable.
- A50ZSDDR: D50 base with sound, addressable.

This device needs an addressable detector “with SIRDR functionality” (standard detectors do not have this functionality) which will allow it to operate as a relay associated to this detector.

Typical uses of the A30XZSDDR and A30XZSLDR are spaces that require integrated fire detection equipment with sounder and visual alarm, such as hotel rooms fitted out for clients with hearing impairments, waiting rooms, nursing rooms, etc.

The coverage of the assembly should not exceed the coverage of the fire detector with which it is installed, unless there is a reason or use that justifies it.

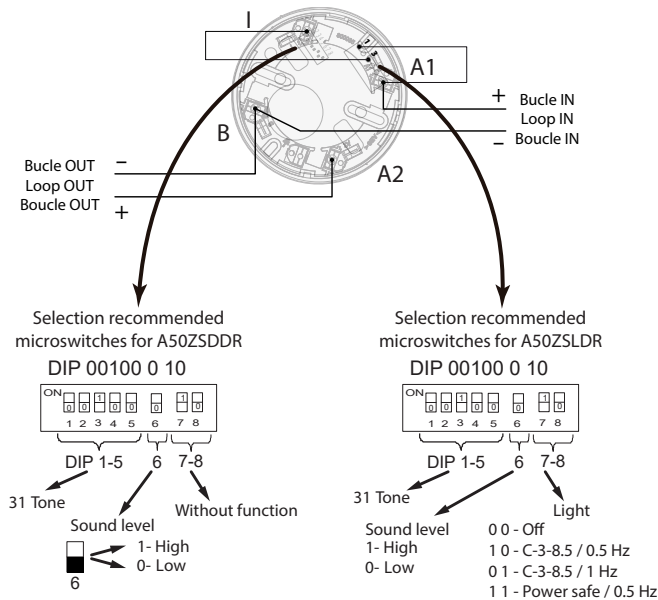

## TECHNICAL FEATURES

	A50ZSDDR	A50ZSLDR
Supply	18-30 V with polarity	18-30 V with polarity
Standby consumption	0 mA	0 mA
Alarm consumption	5 mA / 6 mA (Low/High dB)	19 mA / 20 mA (Low/High dB)
Operating temperature	-10°C +55°C	-10°C +55°C
Dimensions	Ø112mm x alto 43 mm (w/o detector)	Ø112mm x alto 43 mm (w/o detector)
IP protection	IP 21C	IP 21C
Sound intensity	Low 90 / High 96 dB-1m	Low 90 / High 96 dB-1m
Tones	31 types	31 types
Standar	EN 54-3	EN 54-23 and EN 54-3
Flash	-	0,5 Hz (60 ms)



# A30XZSLDR A30XZSDDR



## Addressable alarm devices

Base with EN 54-23 visual alarm certified for A30X series, EN 54-3 sound certified and base detector.

There are 2 models available:

- A30XZSLDR: A30XZ base with sound and light base, addressable.
- A30XZSDDR: A30XZ base with sound, addressable.

This device needs an addressable detector “with SIRDR functionality” (standard detectors do not have this functionality) which will allow it to operate as a relay associated to this detector.

Typical uses of the A30XZSDDR and A30XZSLDR are spaces that require integrated fire detection equipment with sounder and visual alarm, such as hotel rooms fitted out for clients with hearing impairments, waiting rooms, nursing rooms, etc.

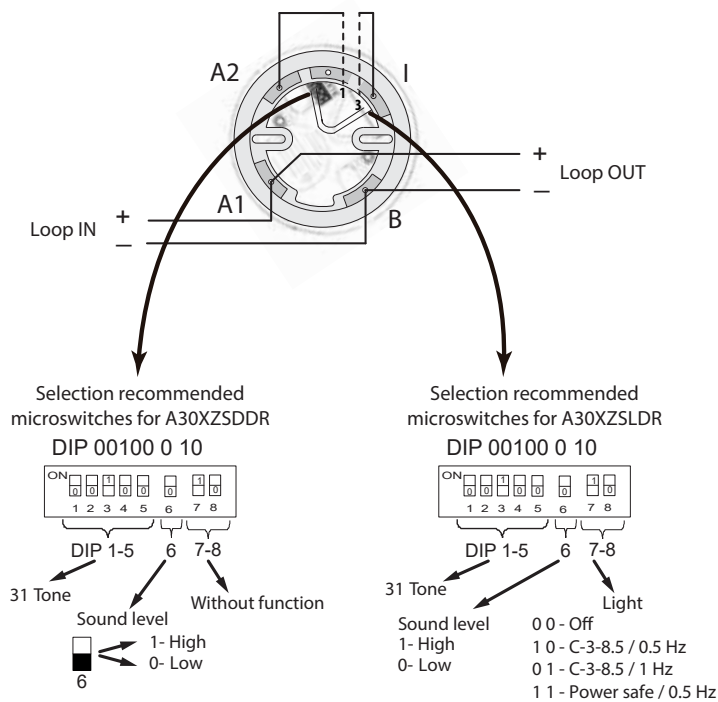

## TECHNICAL FEATURES

	A30XZSDDR	A30XZSLDR
Supply	18-30 V with polarity	18-30 V with polarity
Standby consumption	0 mA	0 mA
Alarm consumption	5 mA / 6 mA (Low/High dB)	19 mA / 20 mA (Low/High dB)
Operating temperature	-10°C +55°C	-10°C +55°C
Dimensions	Ø112mm x high 43 mm (w/o detec.)	Ø112mm x high 43 mm (w/o detec.)
IP protection	IP 21C	IP 21C
Sound intensity	Low 90 / High 96 dB-1m	Low 90 / High 96 dB-1m
Tones	31 types	31 types
Standar	EN 54-3	EN 54-23 and EN 54-3
Flash	-	0,5 Hz (60 ms)

# KABY

## Loop isolator module



Microprocessed algorithmic element installed as another element inside the loop (It is not addressable – There is not need to configure this element).

This is a protection element that is connected into the detection loop, with the aim of isolating stretches with crossed line failures, and allowing therefore the rest of the loop to operate normally.

It is supplied installed inside of a high base. This assembly allows having it in the same place as the detector, making easy the connection of the loop wiring.

We recommend installing a module or element with isolator, minimum every 32 elements of the loop.

The base has two stickers in the outer side with the word "KABY" to allow easy recognition.

The element is feed from the loop connection.

The module is certified according to EN 54-17 Standard, and CE labelled according to the European Regulation of Construction Products (UE) N°305/2011.

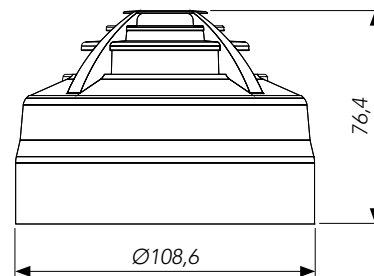
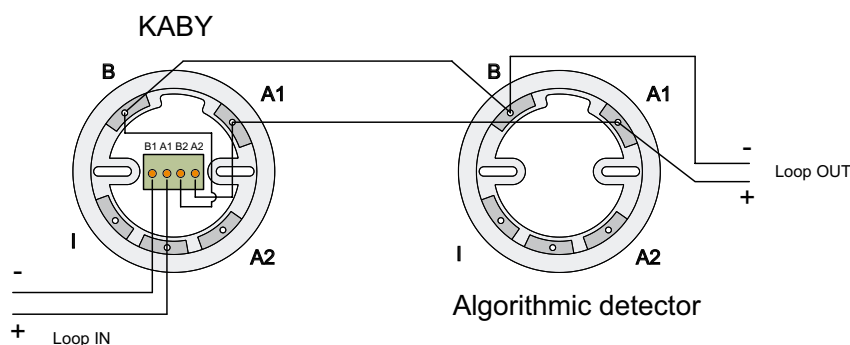

Assembly for  
A30XHA

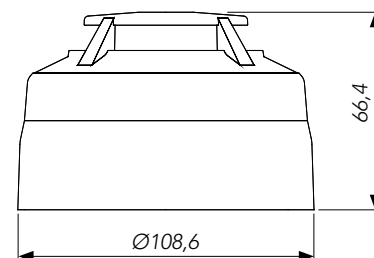

Assembly for A30XTA /  
A30XHAS

### TECHNICAL FEATURES

Power Supply	24 - 35V with polarity
Standby Current	110 $\mu$ A
Short-Circuit Isolator	Yes
Remote Indicator Output	No
Humidity	20 - 95% RH
Temperature	-10°C + 50°C
Standard	EN 54-17
IP Protection	IP 30







**CONVENTIONAL  
SYSTEM**



**CONTROL  
PANELS**



**MODULES  
& DETECTORS**



**MODULES**





# CLVR02-12Z

## Conventional automatic control panel



Automatic conventional fire detection and fire alarm control panel.

This control panel provides different versions to fit more accurately to the needs of each facility:

- CLVR 02Z: CLVR Control panel up to 2 zones.
- CLVR 04Z: CLVR Control panel up to 4 zones.
- CLVR 08Z: CLVR Control panel up to 8 zones.
- CLVR 12Z: CLVR Control panel up to 12 zones.

CLVR control panels features are common in all its models.

Features:

- Control panels up to 12 zones for conventional detectors and call points use.
- 2 supervised sounder outputs, delayed from 0 to 10 minutes, and protected by a fuse.
- 1 alarm output through a dry contact NO/NC (normally open / normally closed).
- 1 fault output through a dry contact NO/NC (normally open / normally closed).
- 2 auxiliary outputs 30V/DC supervised and protected by a fuse to feed external (magnetic fire doors, sounders, etc).
- Available testing mode to facilitate the quick and easy verification of the sensors and call points.
- It allows to configure the open line, alarm detector and alarm call point threshold, to adjust to the operation with other detectors.
- It allows to configure the last detection zone as a supervision input of a external protection fire system with a fault indication.
- Metallic chest with frontal bolted door, 4 predrilled of 28 mm and one rectangular else of 140 x 20 mm for electric wiring and space for 2 batteries of 7Ah.
- RS485 MODBUS protocol on-demand.
- Possibility of software ON-LINE on PC using MODBUS functionality.
- CONTACTID on-demand.
- Certified according to EN 54-2 & EN 54-4 standards and CE mark .

### TECHNICAL FEATURES

<i>Input voltage</i>	110/230VAC 50/60Hz	<i>End of line capacitor</i>	4 K7
<i>Output voltage</i>	21 V Nominal	<i>Sounder output voltage</i>	30 V/DC
<i>Maximum consumption</i>	70 VA to 230 V/AC	<i>Fault output</i>	Yes, dry contact
<i>Batteries</i>	2 x 12 V 7 Ah SLA	<i>Environmental conditions</i>	-10°C +50°C
<i>Max. voltage 30V output</i>	0,75A / 1,50A <sup>(1)</sup> AUTORESET	<i>Size</i>	363 x 331 x 96 mm
<i>Battery charger</i>	500 mA 27 V/DC 20°C	<i>Weight (without batteries)</i>	4,3 Kg
<i>Devices per zone</i>	32	<i>Standar</i>	EN 54-2, EN 54-4 & EN 12094-1
<i>Control panel power supply</i>	2,2 A	<i>Sounder output fuse S1</i>	1A / 1,85A <sup>(1)</sup> Autoreset
<i>Maximum current per zone</i>	2 mA (standby)	<i>Sounder output fuse S2</i>	1A / 0,75A <sup>(1)</sup> Autoreset

<sup>(1)</sup> CLVR08Z and CLVR12Z control panels

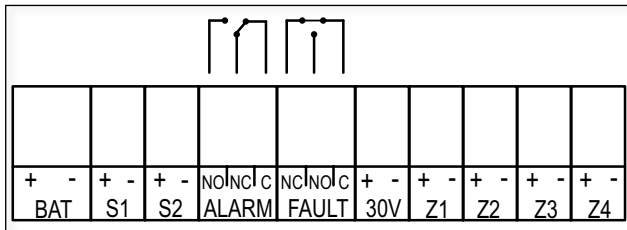

NOTE 1

\* Only CLVR02Z / CLVR04Z

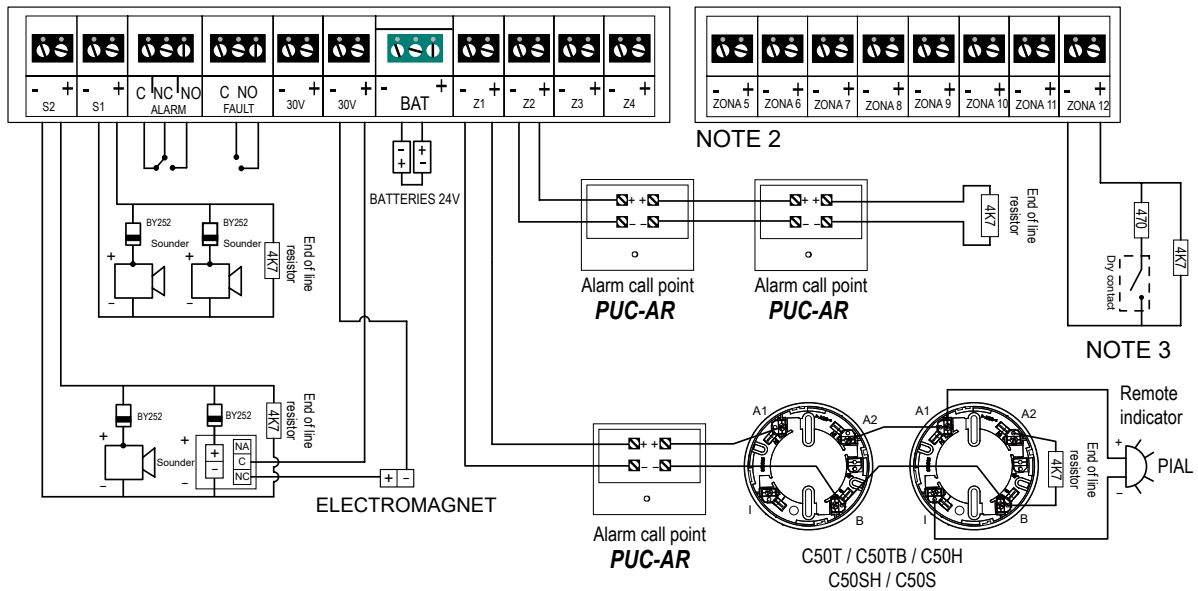
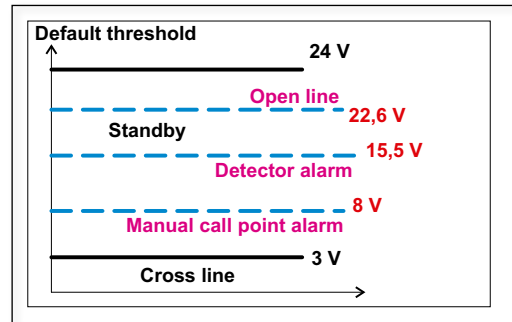

NOTE 1: Zones 3 and 4 are not functional in CLVR02Z control panel.

NOTE 2: This card contains 4 or 8 zones depending on the model (CLVR08Z/CLVR12Z).

NOTE 3: Last zone configured for external system monitoring.

Example of general wiring diagram

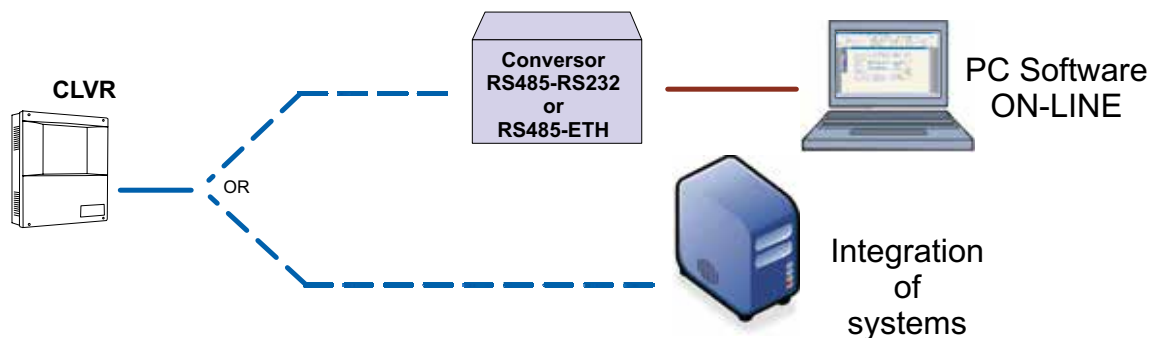

Example of connection for MODBUS functionality



# LONDON

## Automatic conventional control panel



The London control Panel has been designed according EN54 part 2 and 4 in accordance with the last directives, successfully overcoming the most severe tests of environmental conditions, conducted electrical noise, magnetic disturbances, vibration, etc.

Based in a micro processed technology of 16 bits, used this for managing the detection system and performed manoeuvres. It allows conventional detectors, with the following voltage levels:

- Open line	22,5 V	24 V
- Surveillance mode	19 V	22,5 V
- Detector alarm	7 V	16 V
- Call point alarm	3,5 V	7 V
- Crossed line	0 V	3,5 V

Measuring the line voltage and knowing the voltage merges aforementioned, a correspondence can be established with the control panel indication.

### Features:

- Control panel configurable up to 12 modules, with 4 zones or 4 relays (control panel limit of 48 outputs, relays and zones).
- Expandable up to 32 modules with an additional cabinet (limit 128 outputs, zones and relays).
- Supports up to 32 devices (detectors and call points) per zone.
- Configurable with PC-EasyLONDON software (RS232).
- It allows to connect an external keyboard (standard PC-PS2).
- It allows the connection of 10 repeaters.
- 30Vdc auxiliary output.
- Equipped with 1 delayed sounder output (0 to 10 minutes) and supervised.
- Equipped with 1 alarm output and 1 fault output as free voltage relays.
- It allows the connection of a printer (RS232).
- Certified according EN 54-2 and EN 54-4, and CE mark.
- Access to the panel keyboard by means of a numeric code.
- Size: 418 x 324 x 150 mm.

### TECHNICAL FEATURES

<i>Input voltage</i>	230 V 50 Hz/AC	<i>Maximum current per zone</i>	2 mA (standby)
<i>Output voltage</i>	21 V Nominal	<i>End of line capacitor</i>	4 K7
<i>Standby consumption</i>	70 mA	<i>Sounder output voltage</i>	24V/DC 2 A
<i>Alarm consumption</i>	140 mA	<i>Fault output</i>	No
<i>Batteries</i>	2 x 12 V 7 Ah SLA	<i>Environmental conditions</i>	-10°C +50°C
<i>Supply fuse</i>	4 A	<i>Size</i>	418 x 324 x 150 mm
<i>Battery charger</i>	500 mA 27V/DC 20°C	<i>Weight (without batteries)</i>	5.9 Kg
<i>Devices per zone</i>	32	<i>Standard</i>	EN 54 parts 2 & 4
<i>Control panel power supply</i>	3 A	<i>Max. voltage 30V output</i>	1 A

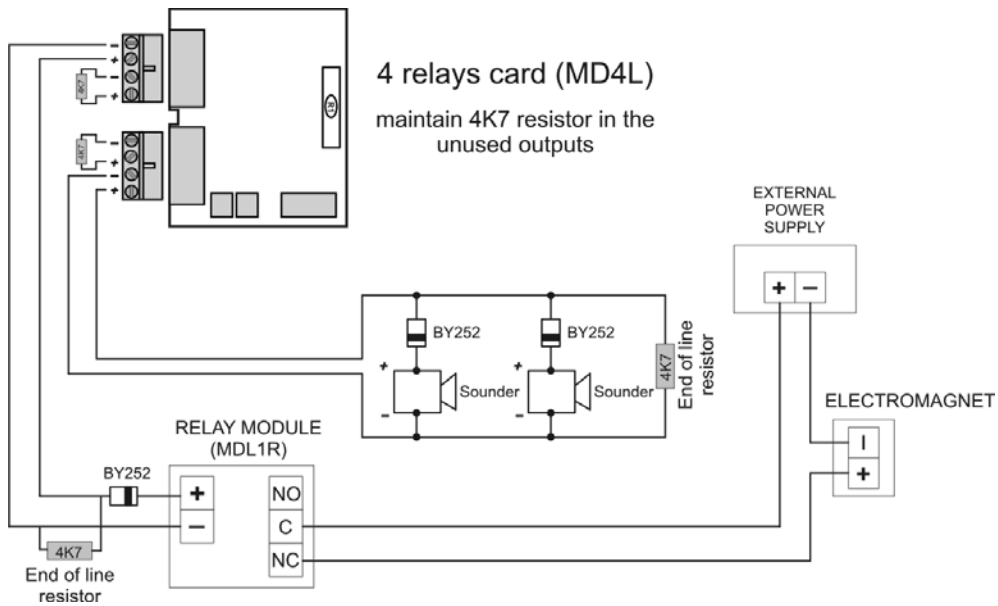

Example of a relay card wiring diagram

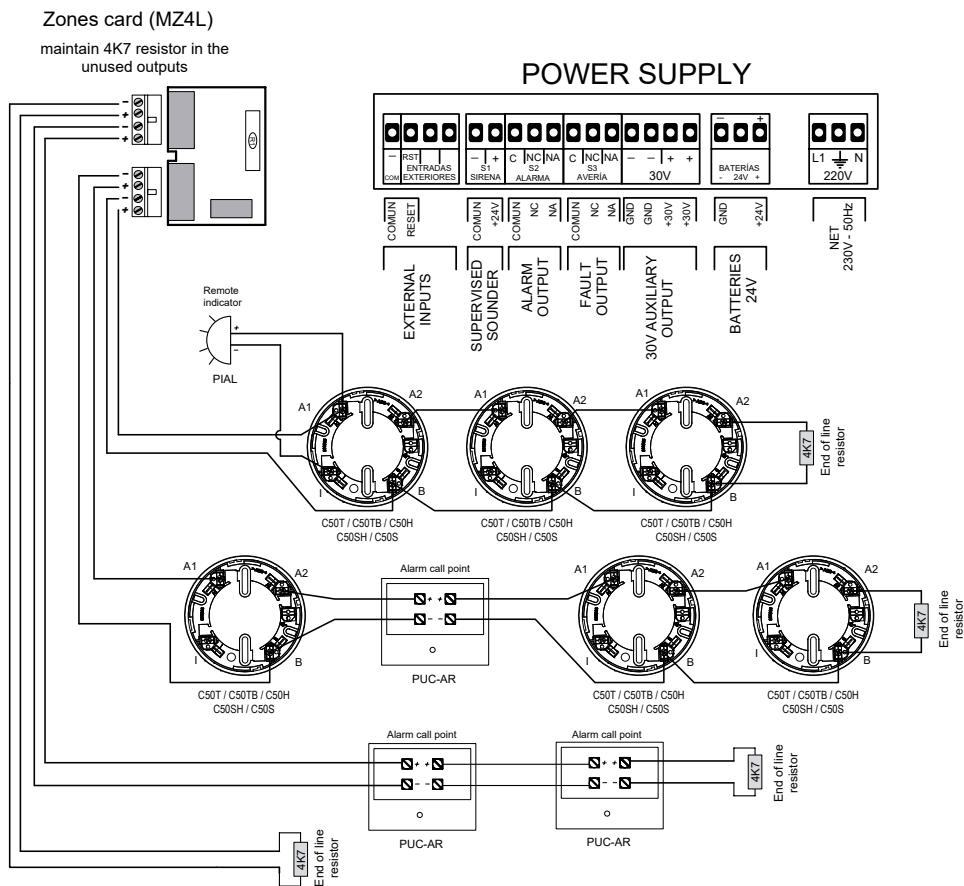

Example of a zones card connection diagram



# EASY LONDON

## Setup software for control panels

EASY LONDON is a support software for programming the London control panel of Cofem.

Since this control panel allows you to control a large number of elements (it could manage 128 outputs between zones and relays), it needs an effective system of labelling and programming for an easy, quickly and intuitive configuration.

You can download EasyLONDON software to any PC.

It allows you to prepare information related to the installation (labels of zones, relays and their activation, modes of operation, etc) on this computer and then dump it on the control panel with an RS232.

This form will be easier to work on the configuration of the control panel in any place where are all the necessary information is available, and only move to the installation for its dump on the control panel and start-up.

In addition, avoids having to enter the information through the front of the control panel, especially useful for complex installations configuration feature.

Similarly, the EasyLONDON facilitates the management and control of the configuration of all the installations with London control panel.

Features:

- Software for the LONDON control panel programming.
- Installable software on any PC (the PC must have minimum characteristics described in the manual of the software EasyLONDON)
- Allows you to easily program the control panel from PC (usually a laptop) in a Windows environment, and connecting with the control panel, then dump this information.
- Connection between PC and control panel with an RS232 connection.
- It allows to easily manage the configurations of all installations with London control panel.
- It avoids having to configure the control panel from the front of it.
- It allows to prepare the configuration from anywhere.
- It allows to prepare the configuration from anywhere.

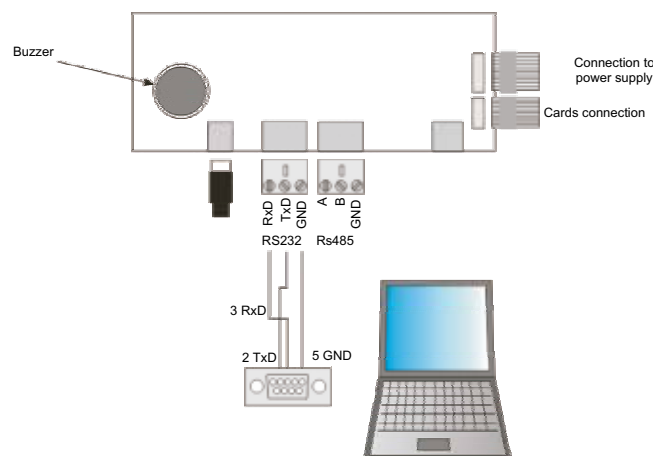

# CDLR

## London repeater control panel



The London control panel allows to connecting up to 10 repeaters, using a 4 wires of 1,5 mm<sup>2</sup> connection (two for supply and two for communication for RS485 line). The two wires of the RS485 line will be connected from the control panel to the corresponding repeaters.

The two wires will connect from the 30V output of the power supply in the control panel to the back panel of their repeaters.

The repeater wiring is realized like the figure attached.

The supply up to 3 repeaters is doing from the 30V output of the power supply of the London control panel.

To feed 4 to 10 repeaters must be done from the 30V output of an external power supply (FAE).

The wiring of repeaters, communication and power wires, will be realized with twisted and shielded halogen-free of 2 x 1,5 mm<sup>2</sup> wire, maximum length up to 1200 m.

### TECHNICAL FEATURES

Supply	30 V
Consumption in surveillance	150 mA
Humidity	20 - 95% RH
Temperature	-10°C +50°C
Dimensions	418 x 324 x 150mm
Weight (without batteries)	4,9 kg
IP protection	IP 30

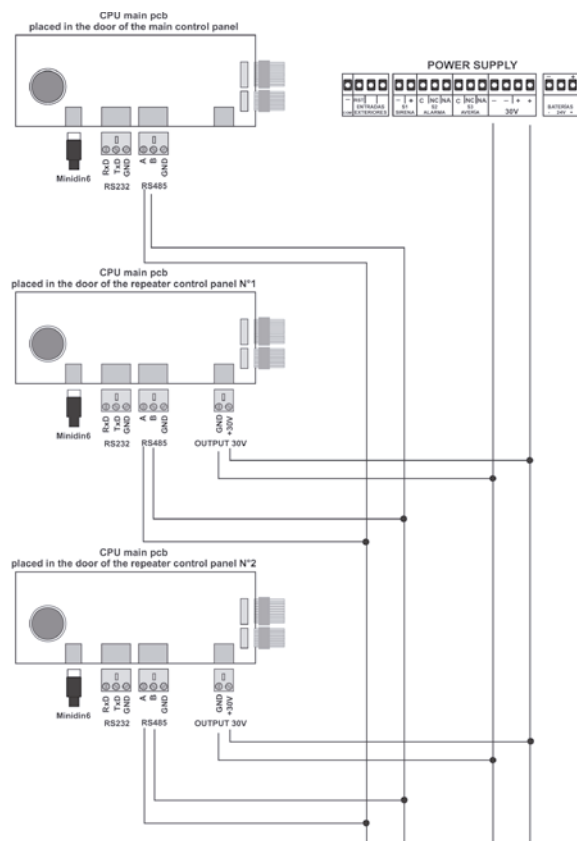



# MCCRC

## Alarm receiving center conventional connection module



Conventional module for connecting with Alarm Receiving Center.

EN 54-21 certified card that allows connection of the CLVR model conventional control panel with an Alarm Receiving Centre (ARC).

The following factory options are available which include the control panel with MODBUS functionality required for communication with the MCCRC card and the MCCRC card.

- CLVR04CRI
- CLVR08CRI\*
- CLVR12CRI\*

\*Note: These control panels do not have space for batteries inside.

The MCCRC card is available for spare parts.

The MCCRC card can only be connected to CLVR control panels with MODBUS functionality.

Features:

- Certified EN 54-21
- Communication with ContactID protocol.
- GPRS and ethernet connection (selectable).
- Notification to the ARC of selected and scheduled events.
- User notification via SMS, e-mail or customised mobile application.
- Software programming on PC via PC port or remote connection.
- Remote access and control of control panel status.





# PUCAR

## Manual call point



Manual call point for the conventional fire detection system.

It has an indicator of action (red led) that illuminates in case of be manually operated (alarm).

Features:

- Resettable call point by pushing yellow button on the front side.
- Transparent protector cover to avoid accidental false alarms.
- Immediate visual recognition of alarm status by the permanent activation of the LED, and the trigger of
- The yellow tab on the lower side of the activation face.
- According to EN 54-11 and CE mark according the European Regulation of Construction Products (UE N°305/2011).

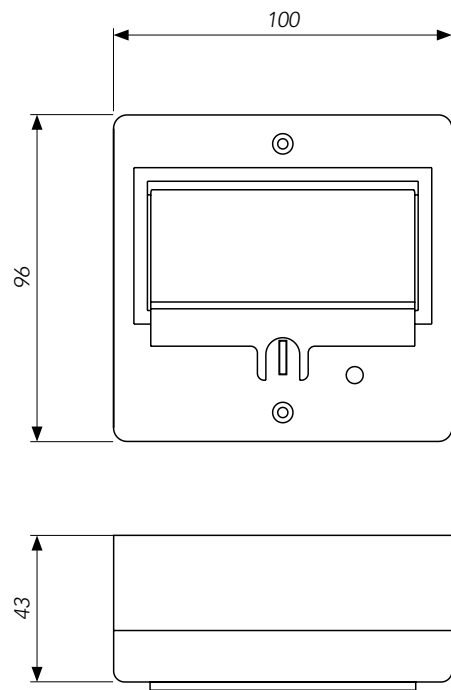
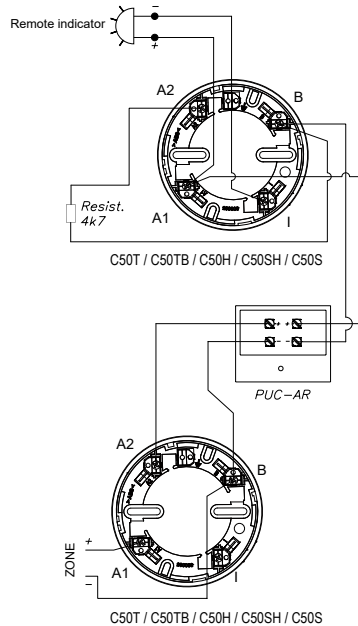

### TECHNICAL FEATURES

Supply	24 - 35V with polarity
Standby consumption	0 mA
Alarm consumption	35 mA
Activation signal	Red led
Remote indicator output	No
Humidity	20 - 95% RH
Temperature	-10°C +50°C
Standard	EN 54-11
IP protection	IP 50



# C50SH

## Conventional smoke and heat detector



Conventional smoke and Heat detector

The C50 family of detectors are based on a new refined aesthetic that integrates the latest electronic technology with new, more efficient detection algorithms and a three-dimensional design that makes it more robust against environmental dirt.

The C50 family allows multiple combinations between smoke and heat detection.

The C50SH model is a detector with two different types of sensors: An smoke sensor and a heat sensor.

The smoke sensor is specially designed to detect the presence of combustion aerosols in a three-dimensional design that makes it more robust against dirt.

Regarding heat sensor, it allows the thermovelocimetric response of the detector, reaching the alarm status with a static temperature of 60°C in the case of slow fire developments.

Features:

- Smoke and heat sensor.
- Low profile, total height less than 55 mm (including low base).
- Also available with high base for 20 mm tube.
- Possibility of connection to a remote action indicator.
- Easy connection, without polarity.
- Red LED on to indicate its alarm status.
- Standby status signalled by simple flashing of the red led every 10 seconds.
- High level of dirt status signalled by double flashing of the red LED every 10 seconds.
- Easy installation of head and plinth, interchangeable throughout the C50 family, and made of white heat-resistant ABS.
- Certified by AENOR according to Standard EN 54-5 class A2R and EN 54-7 with CE marking according to the European Regulation on Construction Products (EU) No. 305/2011.

### TECHNICAL FEATURES

Power supply	12-30 V without polarity
Standby current	30 $\mu$ A (at 18V)
Alarm current	35 mA (at 18V)
Activation signal	Red light
Remote indicator	Yes
Humidity	20 - 95% RH
Temperature operative	-10°C +50°C
Stockage temperature	-10°C +55°C
Sensitivity	EN 54-5 Class A2R
IP protection	IP 20

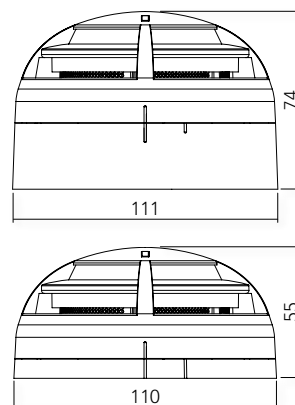



# C50S

## Conventional smoke detector



Conventional smoke detector

The C50 family of detectors are based on a new refined aesthetic that integrates the latest electronic technology with new, more efficient detection algorithms and a three-dimensional design that makes it more robust against environmental dirt.

The C50 family allows multiple combinations between smoke and heat detection.

The C50S model is a detector with a smoke sensor.

The sensor is specially designed to detect the presence of combustion aerosols in a three-dimensional design that makes it more robust against dirt.

Features:

- Smoke sensor.
- Low profile, total height less than 42 mm (including low base).
- Also available with high base for 20 mm tube.
- Possibility of connection to a remote action indicator.
- Easy connection, without polarity.
- Red LED on to indicate its alarm status.
- Standby status signalled by simple flashing of the red led every 10 seconds.
- High level of dirt status signalled by double flashing of the red LED every 10 seconds.
- Easy installation of head and base, interchangeable throughout the C50 family, and made of white heat-resistant ABS.
- Certified by AENOR according to Standard EN 54-7 with CE marking according to the European Regulation on Construction Products (EU) No. 305/2011.

### TECHNICAL FEATURES

Power supply	12-30 V without polarity
Standby current	30 $\mu$ A (at 18V)
Alarm current	35 mA (at 18V)
Activation signal	Red light
Remote indicator	Yes
Humidity	20 - 95% RH
Temperature operative	-10°C +50°C
Stockage temperature	-10°C +55°C
Sensitivity	EN 54-7
IP protection	IP 20

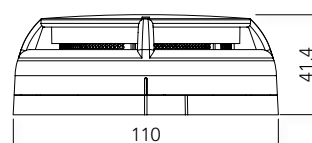
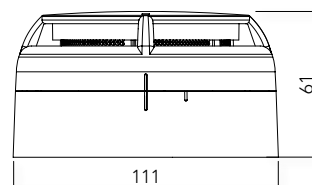



## C50T/C50TB

### Conventional temperature detector



Conventional temperature detector.

The C50 family of detectors are based on a new refined aesthetic that integrates the latest electronic technology with new, more efficient detection algorithms and a three-dimensional design that makes it more robust against environmental dirt.

The C50 family allows multiple combinations between smoke and heat detection.

The C50T and C50TB models are detectors with a temperature sensor.

The temperature sensor of C50T is set to reach the alarm status with a static ambient temperature of 60°C.

In certain circumstances, the premises or building may require detectors that go into alarm status at a temperature higher than normal. In this case, the C50TB temperature sensor responds according to the ambient temperature, reaching the alarm status when the static temperature is 70°C in the case of slow fire developments.

Features:

- Heat sensor.
- Low profile, total height less than 42 mm (including low base).
- Also available with high base for 20 mm tube.
- Possibility of connection to a remote action indicator.
- Easy connection, without polarity.
- Red LED on to indicate its alarm status.
- Standby status signalled by simple flashing of the red led every 10 seconds.
- Dirty status signalled by a double flashing of the led every 10 seconds.
- Easy installation of head and base, interchangeable throughout the C50 family, and made of white heat-resistant ABS.
- Certified by AENOR according to Standard EN 54-5 class A2 with CE marking according to the European Regulation on Construction Products (EU) No. 305/2011.

#### TECHNICAL FEATURES

Power supply	12-30 V without polarity
Standby current	30 $\mu$ A (at 18V)
Alarm current	35 mA (at 18V)
Activation signal	Red light
Remote indicator	Yes
Humidity	20 - 95% RH
Temperature operative	-10°C +50°C
Stockage temperature	-10°C +55°C
Sensitivity	EN 54-5 Class A2
IP protection	IP 20

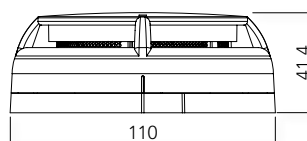
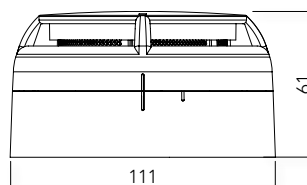

# C50H

## Conventional heat detector



Conventional heat detector

The C50 family of detectors are based on a new refined aesthetic that integrates the latest electronic technology with new, more efficient detection algorithms and a three-dimensional design that makes it more robust against environmental dirt.

The C50 family allows multiple combinations between smoke and heat detection.

The C50H model is a detector with a heat sensor.

The heat sensor allows the detector's thermovelocimetric response, reaching the alarm status with a static temperature of 60°C in the case of slow fire developments.

Features:

- Heat sensor.
- Low profile, total height less than 42 mm (including low base).
- Also available with high base for 20 mm tube.
- Possibility of connection to a remote action indicator.
- Easy connection, without polarity.
- Red LED on to indicate its alarm status.
- Standby status signalled by simple flashing of the red led every 10 seconds.
- Easy installation of head and base, interchangeable throughout the C50 family, and made of white heat-resistant ABS.
- Certified by AENOR according to Standard EN 54-5 class A2 with CE marking according to the European Regulation on Construction Products (EU) No. 305/2011.

### TECHNICAL FEATURES

Power supply	12-30 V without polarity
Standby current	30 $\mu$ A (at 18V)
Alarm current	35 mA (at 18V)
Activation signal	Red light
Remote indicator	Yes
Humidity	20 - 95% RH
Temperature operative	-10°C +50°C
Stockage temperature	-10°C +55°C
Sensitivity	EN 54-5 Class A2R
IP protection	IP 20

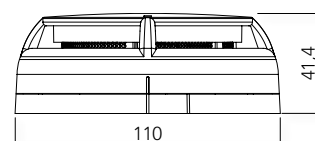
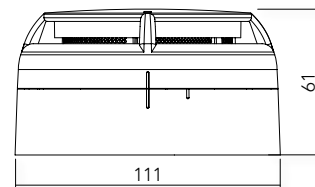

# PIAL

## Remote indicator



Remote action indicator of fire detection system.

The PIAL allows showing alarm status of sensors and modules of analogue systems, as well as of sensors of conventional systems.

Typical cases of use:

- Places where elements of the detection system are not visible, for example, inside false ceiling, in which the PIAL can be visibly situated on the lower part of the ceiling or near the wall.
- Reduced accessibility rooms or that is needed do a big inspection range for the identification of the element in alarm, for example in hotel rooms, where the PIAL can be situated above the door frame of each room, making very easy its identification.

Permanent activation of the red LED indicates alarm status.

It is an element easy to install, both for its electrical wiring and its fixation, furthermore, can be adapted to the conduit boxes and switchgear.

Features:

- Alarm status can be identified in any perpendicular direction at its installation.
- Easy connection, with polarity.
- Can be adapted to the conduit boxes and switchgear.
- The red light is produced by two LEDs, increasing reliability against failure of any of them.
- Manufactured in heat-resistant ABS. Base and lid are white, red viewer.

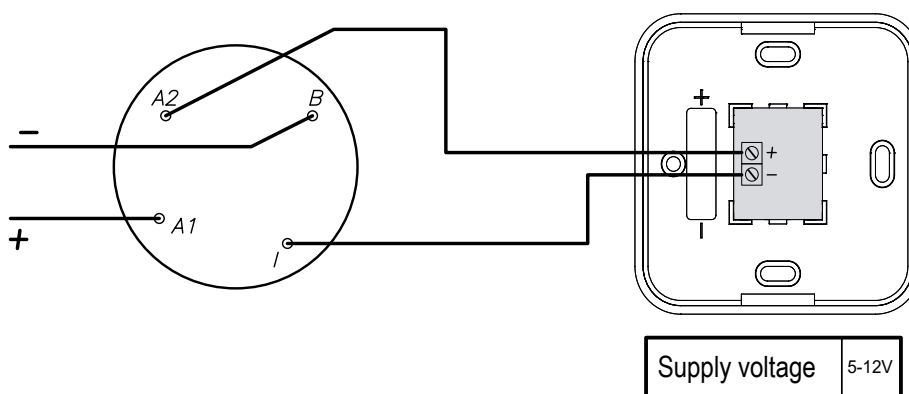

### TECHNICAL FEATURES

Supply	5 - 12 V/DC with polarity
Standby consumption	0 mA
Alarm consumption	5 mA
Activation signal	Red led
Humidity	20 - 95% RH
Temperature	-10°C +50°C
IP protection	IP 50



# C50ZSL C50ZSD



## Conventional alarm devices

Base for C50 conventional detectors with EN 54-23 certified visual alarm base and EN 54-3.

There are 2 models available:

- C50ZSL: D50 base with sound and light base, addressable.
- C50ZSD: D50 base with sound, addressable.

Typical uses of the C50ZSL and C50ZSD are spaces that require integrated fire detection equipment with sounder and visual alarm, such as hotel rooms fitted out for clients with hearing impairments, waiting rooms, nursing rooms, etc.

The coverage of the assembly should not exceed the coverage of the fire detector with which it is installed, unless there is a reason or use that justifies it.

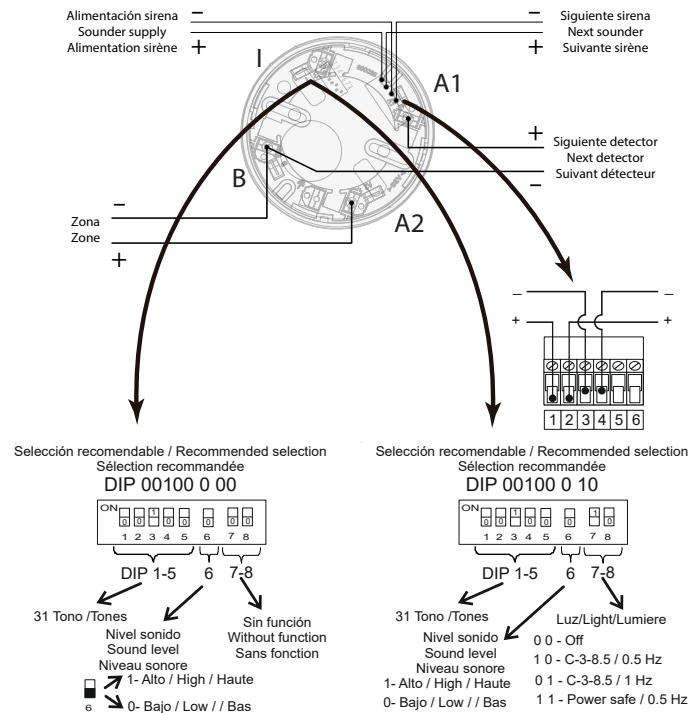

## TECHNICAL FEATURES

	C50ZSD	C50ZSL
Supply	18-30 V with polarity	18-30 V with polarity
Standby consumption	0 mA	0 mA
Alarm consumption	5 mA / 6 mA (Low/High dB)	19 mA / 20 mA (Low/High dB)
Operating temperature	-10°C +55°C	-10°C +55°C
Dimensions	Ø112mm x alto 43 mm (w/o detector)	Ø112mm x alto 43 mm (w/o detector)
IP protection	IP 21C	IP 21C
Sound intensity	Low 90 / High 96 dB-1m	Low 90 / High 96 dB-1m
Tones	31 types	31 types
Standar	EN 54-3	EN 54-23 and EN 54-3
Flash	-	0,5 Hz (60 ms)





**ACCESSORIES**



**BEAM  
DETECTORS**



**ALARM  
DEVICES**

**POWER  
SUPPLY**





# A50BI

## Socket adapter



To facilitate the task of updating the A30X system to the new A50 range detectors, Cofem has an "interconnection base" that allows for placing the detectors of the algorithmic-addressable and conventional system directly on the sockets of higher systems without the need to change or rewire the sockets.

Thus, if the wiring and the sockets of the installation are in good condition, a quick, simple and very cheap update to the system can be carried out, based on replacing the fire detection and alarm control panel and its detectors.

The A30XBI adaptor can be used with conventional and algorithmic-addressable detectors and these are supplied configured according to the detectors to be replaced.

A50 detector

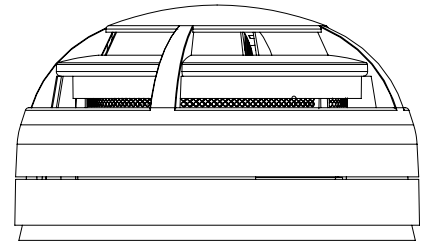
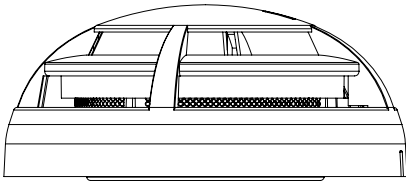

A50BI adapter

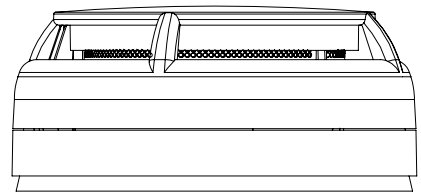
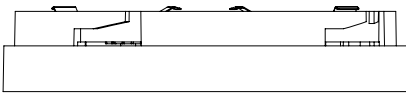

Base (A30XZO - A30XZAL)

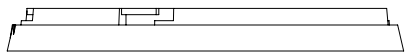

Assembly diagram



# A30XBI

## Socket adapter



To facilitate the task of updating the TC25/A system to the Lyon system (and in general the conventional system), Cofem has an "interconnection base" that allows for placing the detectors of the algorithmic-addressable and conventional system directly on the sockets of higher systems without the need to change or rewire the sockets.

Thus, if the wiring and the sockets of the installation are in good condition, a quick, simple and very cheap update to the system can be carried out, based on replacing the fire detection and alarm control panel and its detectors.

The A30XBI adaptor can be used with conventional and algorithmic-addressable detectors and these are supplied configured according to the detectors to be replaced.

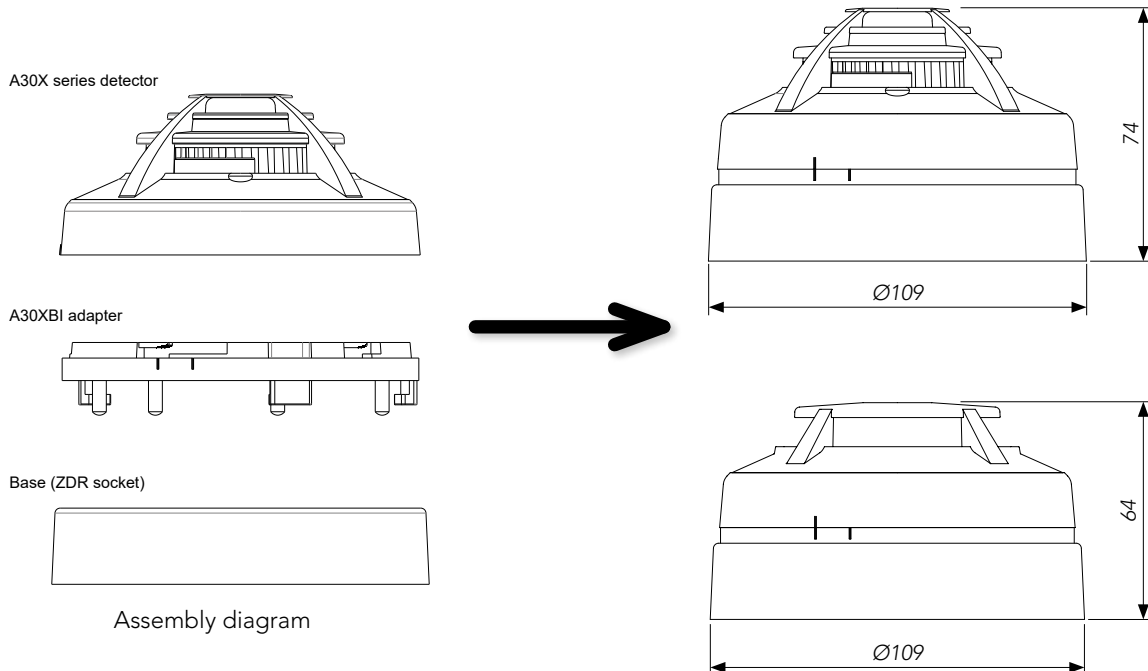



# MDL1R MDL2R MDL-8

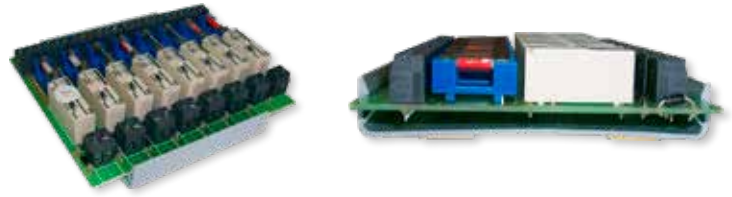

### Relays module

Relay module for fire detection system.

This module consists of a relay that controls the output of a dry contact normally open (NO) normally closed (NC), unsupervised.

That provision allows you to control as typical application door electromagnets in conventional fire detection systems, either through the control panel supply or sources of external power supply (FAE).

The equipment is very simple and easy to install.

The board of the relay module is mounted on a plastic base, which carries some tapes that allow secure comfortably in the place that best suits, taking advantage of the available space in stations, power supplies (FAE), etc, according to the normal distribution of the wiring of the installation.

In addition, the relay module contains a safety fuse on the side of the dry contact.

There are three versions of modules based on the number of relays contained on the base:

- MDL1R: 1 relay module.
- MDL2R: 2 relays module.
- MDL-8: 8 relays module.

Features:

- Relay with dry contact output NO-NC, not supervised.
- Simple installation by means of adhesive tapes, taking advantage of the space and following the normal distribution wiring.
- It contains safety fuse.

### TECHNICAL FEATURES

Supply	24 - 35V
Standby consumption	0 mA
Fuse	2 A
Consumption active	20 mA
Dry contact output	30 Vdc / 230 Vac 2A

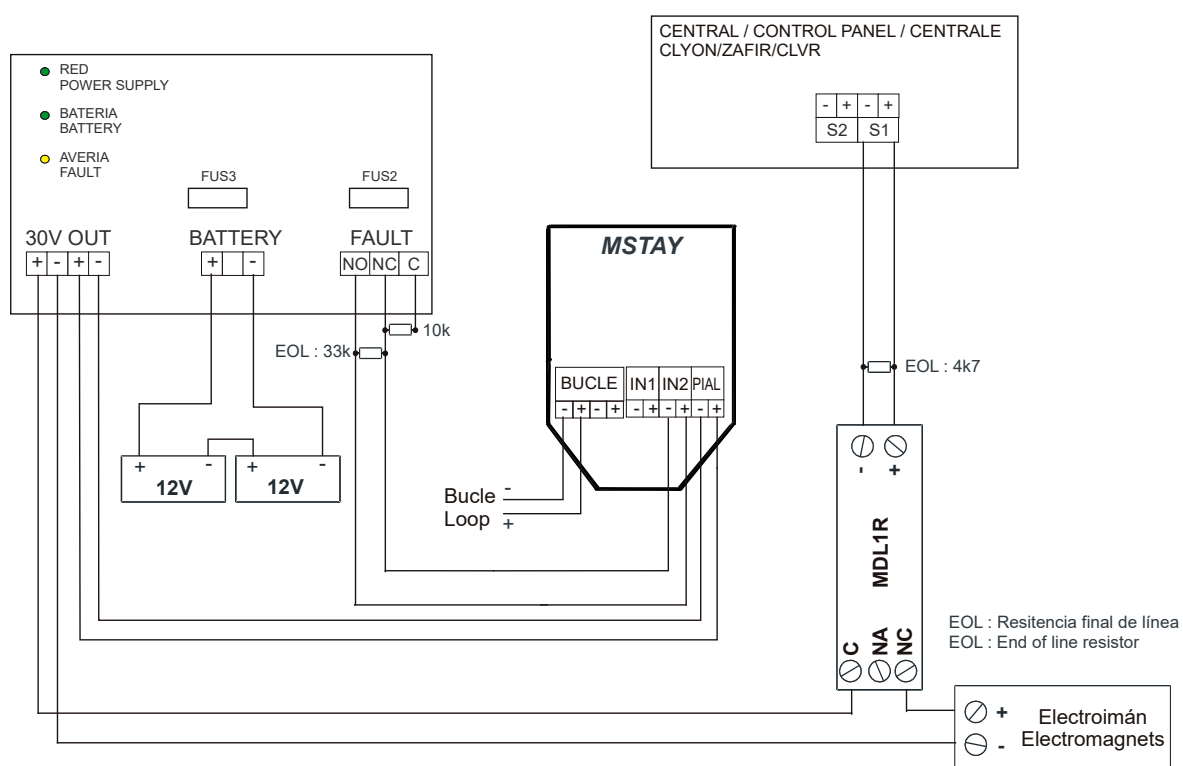

Diagram connexion



# CA6 SIR24F SIR24P



## Indoor sounders

Sound level (dB-(A))	Distance (m)
120	1
114	2
108	4
102	8
96	16
90	32
84	64

### ACOUSTIC GENERAL RULES

- Every time you double the distance, 6 dBs are lost.
- 30 dBs are lost for every fire door.
- 20 dBs are lost for every normal door.

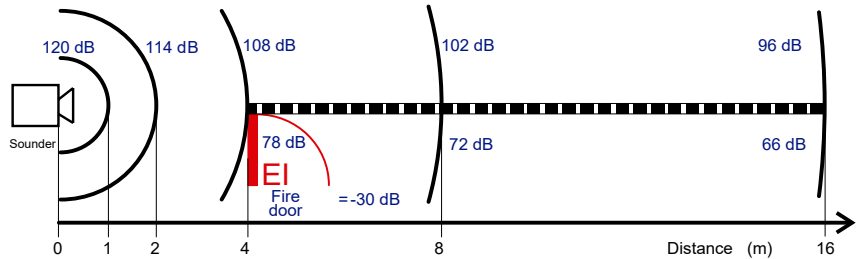

Indoor sounders to be directly connected to the output of control panels or relay modules.

#### ALARM BELL 6" CA6

Output voltage	24 Vcc
Consumption	25 mA
Output volume	95 dBA at 1 meter 92 dBA at 3 meters
Operative temperature	-20°C to 60°C
Humidity	Max. 90% RH
Size	6" (150 mm x 56 mm)
Weight	764g
IP protection	IP33

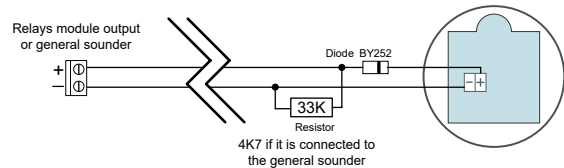

#### SIR24P & SIR24F SOUNDERS

Material	red P.V.C.
Operating voltage	30 Vdc
Consumption at 30 Vdc	70 mA
Sound level	85 dB
Operating temperature	5°C to 40°C
Size	80 x 80 x 30 mm
With intermittent flash	Only SIR24F model

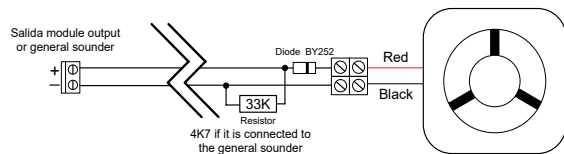

# SIR24B SIR24BL SIR24B+BSLC SIR24C



## Indoor and outdoor sounders

List of indoor and outdoor sounders to connect directly to the sounder output of the control panels or relay modules.

SOUNDER SIR24B, SIR24BL, SIR24BZA and BSLC

- Indoor and outdoor sounder made of red ABS.
- Great sound level. Low consumption.
- 32 selectable tones. Volume control.
- Automatic synchronization.
- SIR24B: Sounder.
- SIR24C: Sounder with light, certified EN54-23.
- SIR24BL: Sounder with light.
- SIR24BZA: Sounder with high base.
- BSLC: Base with light, certified EN54-23.
- All sounders have a diode incorporated.

Voltage range	9-28 Vdc
Consumption: (Using tone 3)	at 24Vdc 16mA (SIR24B) 20mA (SIR24BL) 49mA (SIR24C)
(Using tone7) Consumption: (Tone 3/0,5Hz/high power)	at 24Vdc 32mA (SIR24B+BSLC)
Output volume	at 24 Vdc 102 dB (A) (tone 3) SIR24C 107dB (tone 23)
Operating temperature	-25°C at +70°C
Size	Ø95 x 91 mm Ø95 x 107 mm (SIR24BL/SIR24BZA) Ø95 x 95 x 135 mm (SIR24B+BSLC) Ø100 x 98 mm (SIR24C)
IP protection	IP54-SIR24B IP65-SIR24BL IP65-SIR24BZA IP65-SIR24B+BSLC IP21C-SIR24C (low base) IP65-SIR24C (high base)

### SIR24B + BSLC SOUNDER

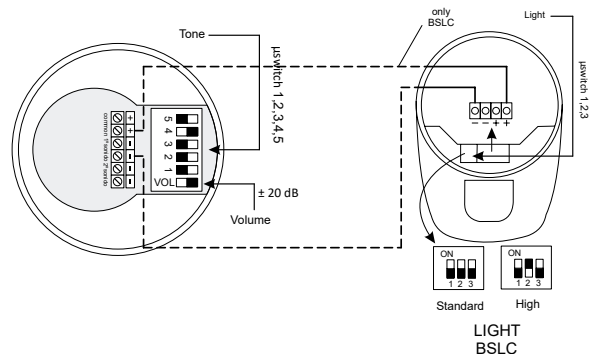

### SIR24B, SIR24BL & SIR24BZA SOUNDERS

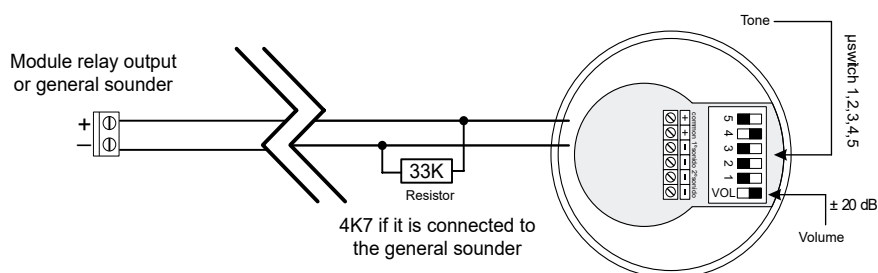

# SIR24SC

# SIR24SC+SIR24SLC

## Voice alarm devices

Device that activates a voice message with sound of fire alarm.

The message is selectable from its internal list.  
They have a diode incorporated.

### A. SIR24SC and SIR24SC+SIR24SLC:

- Voltage: 18 ÷ 28 Vdc.
- Consumption: 4 ÷ 8 mA.
- Sound: 90/100 dB selectable.
- Several selectable alarm tones.
- Temperature: -10°C a 55°C.
- Protection: IP21C.
- Color: red.
- Dimensions: 106 x 106 x 91mm.



### B. SIR24SC + SIR24SLC:

Set alarm voice with bright warning based device.

- Certified EN54-23.
- W 2,4 - 7,5.
- Consumption: 18 ÷ 28 mA.
- 1 Hz (0,5 Hz selectable).

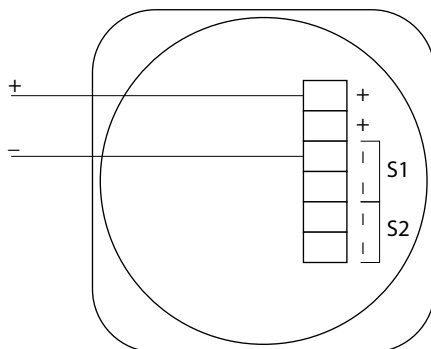

DIAGRAM FOR SIR24SC





# SIRCEI SIRWAL SIR-PIT



## Light warning devices

Luminous warning devices:

Devices that when are activated emit flashes of light in order to alert people with hearing disabilities:

### A. SIRWAL and SIRCEI:

- Certified EN54-23.
- Supply: 9 ÷ 60 Vdc.
- Operating temperature: -25°C to 70°C.
- High base.
- Protection IP65.
- Red color.
- Dimensions: Ø93 mm x 65 mm.
- Flash: White 1Hz (0,5 Hz selectable).
- Consumption: 10-25 mA according selection.
- They have a diode incorporated.

#### A1. SIRWAL:

- Wall device.
- W 2,4 - 7,5.

#### A2. SIRCEI:

- Ceiling device.
- C 3 - 7,5.

### B. SIR-PIT:

- Supply: 9 - 60 Vdc.
- Consumption: 3 ÷ 15 mA according selection.
- Flash: 1 flash 1Hz.  
2 flashes 1Hz.  
Continuous 1Hz.
- Temperature: -20°C to 55°C.
- Protection: IP21C.
- Color: red.
- Red flash.

DIAGRAM FOR SIRWAL AND SIRCEI

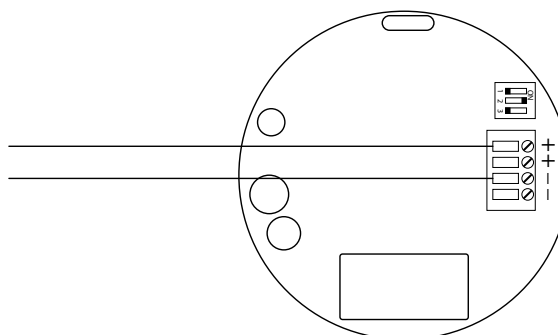
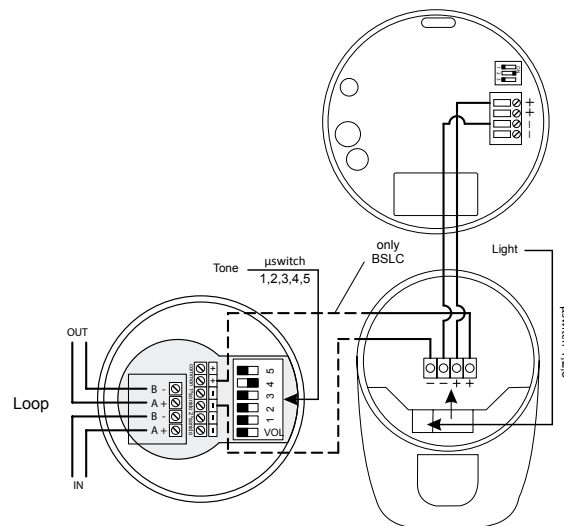

DIAGRAM FOR SIRWAL AND SIRCEI WITH BSCL AND SIRAY



NOTE: They can be connected with the SIRAYBSLC by selecting low sound and light on this device and BSCL. The calculation of consumption points of the SIRAY+BSCL and this additional device shall be computed as a SIRAY+BSCL with selection of sound and maximum light.



# CAEC

## Outdoor sounder



### OUTDOOR SOUNDER CAEC

- Outdoor red sounder made in ABS plastic.
- Internal cover to protect all pcb's
- 24V power sounders.
- Piezoelectric speaker.
- EN54-3 type B certified.

Activation	Via power supply application
Supply	24 Vcc
Power	92 dB
Timing by cycle	3/15 minutes
LED's	1 led bar
Dimensions	260 x 275 x 55 mm
Current / consumption	200 mA
IP protection	IP44

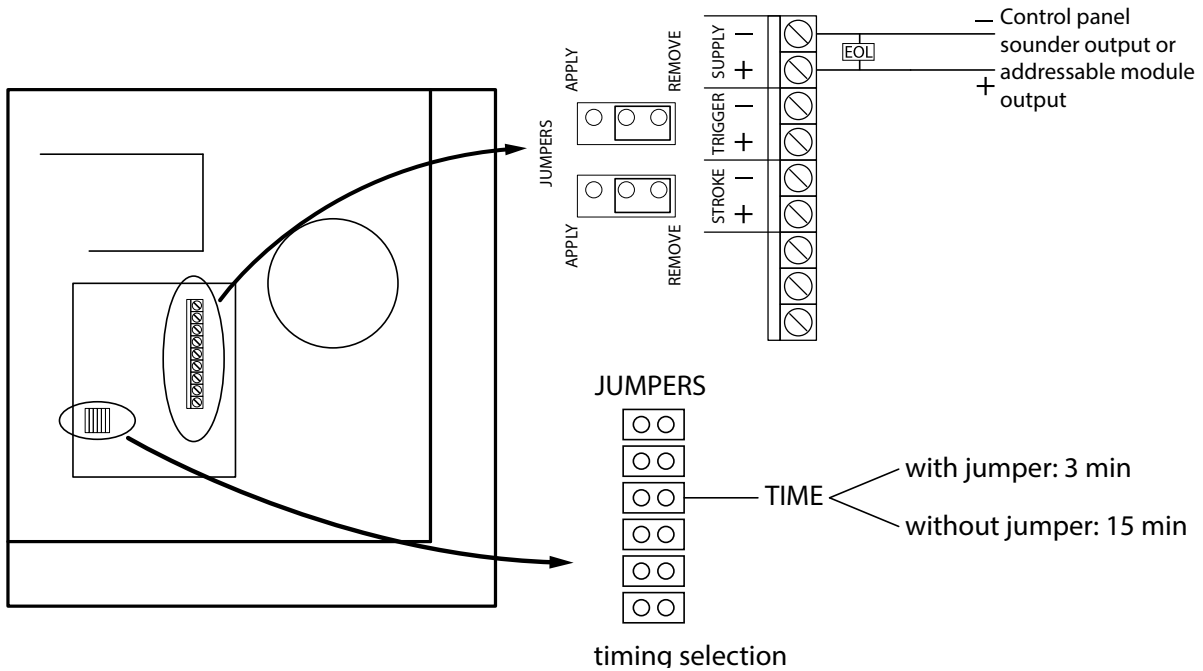

**NOTE:**

EOL: 33KΩ supply by addressable algorithmic modules.  
 EOL: 4K7 Cofem fire control panel sounder general output.



# PWS03/05

## External power supply



External switched-mode power supply.

There are 2 models depending on the system's power requirements:

- PWS03: 3A (100W) supply capacity.
- PWS05: 5A (155W) supply capacity.

The PWS is offered installed inside a 416x321x132 mm cabinet (without inside door), which provides additional space for the necessary batteries inside.

Features:

- Supply capacity of 3A (PWS03 model) or 5A (PWS05 model).
- PWS incorporated in a cabinet, which allows the necessary batteries to be installed inside it.
- Metallic cabinet.
- Incorporated battery charger
- Existing variant with London finish cabinet (FAE03Y / 05Y).

Wiring diagram  
PWS03/05 with relay modules

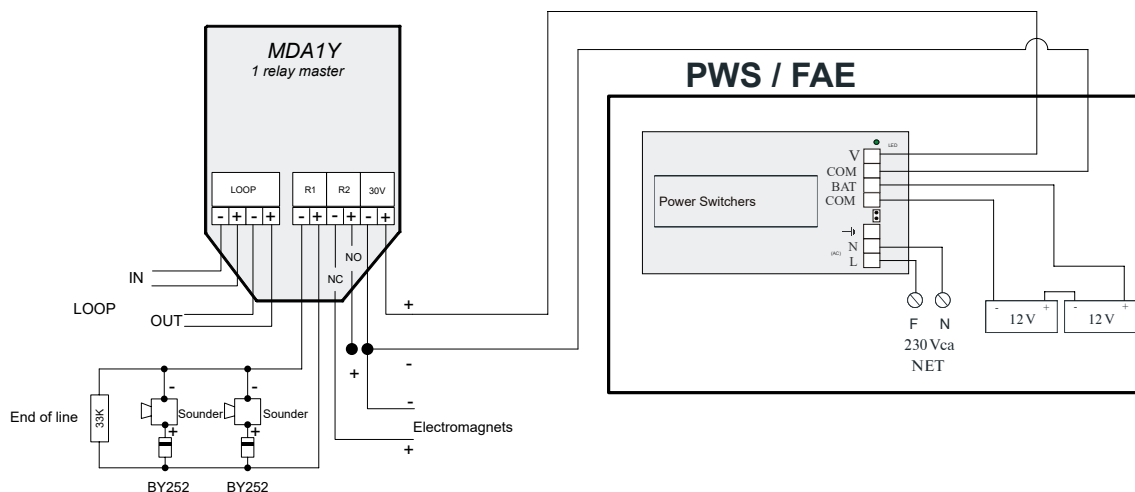

### TECHNICAL FEATURES

Supply	230 V/AC 50 Hz
Output voltage	30 V/DC
Standby consumption	100 mA
Output current	FAE 03: 3A / FAE 05: 5A
Battery charger	Yes
Humidity	20 - 95% RH
Temperature	-10°C +50°C
Dimensions	416x321x132 mm (without door)
IP protection	IP 30



# ZAFIRPWS

## External power supply



External Power Supply (with batteries charge incorporated) for fire detection and fire alarm systems. Certified according to EN 54-4.

This equipment is specially recommended for properly feeding any fire detection device which requires external power supply.

It has two outputs:

- 30V output monitored and protected by a fuse, for easy connection.
- Dry contact fault output, for integration with other systems.

The system has three indication leds to show system status:



RED (green): system operating through 110/230 V/AC power supply.



BATTERY (green): system operating under batteries.



FAULT (amber): system fault, general power supply fault or fault in the auxiliary battery supply.

There are 2 models available depending on the needs of the system:

- ZAFIRPWS2 (65W): supply capacity 1,5A (65w).
- ZAFIRPWS5 (150W): supply capacity 4A (150w).

General power supply connection is different between the two models. ZAFIRPWS2 is connected to electrical network by a connector located on the right side of the box. ZAFIRPWS5 is connected to electrical network directly to the switching power supply.

External Power Supply is placed inside a metallic box of 363 x 331 x 96 mm, which allow additional space for installing batteries (2x12 Vdc7Ah).

### TECHNICAL FEATURES

Power supply	110/230V 50-60Hz/AC
Consumption in standby	50 mA
Output voltage	29 ~ 29,5 VDC
Output current	ZAFIRPWS2: 1,5A ZAFIRPWS5: 4A
Batteries charger	Yes
Humidity	20 - 95% HR
Temperature	-10°C to +50°C
Dimensions	363 x 331 x 96 mm
IP protection	IP 30
Standard	EN 54-4



ZAFIRPWS WIRING DIAGRAM ALGORITHMIC ADDRESSABLE SYSTEM

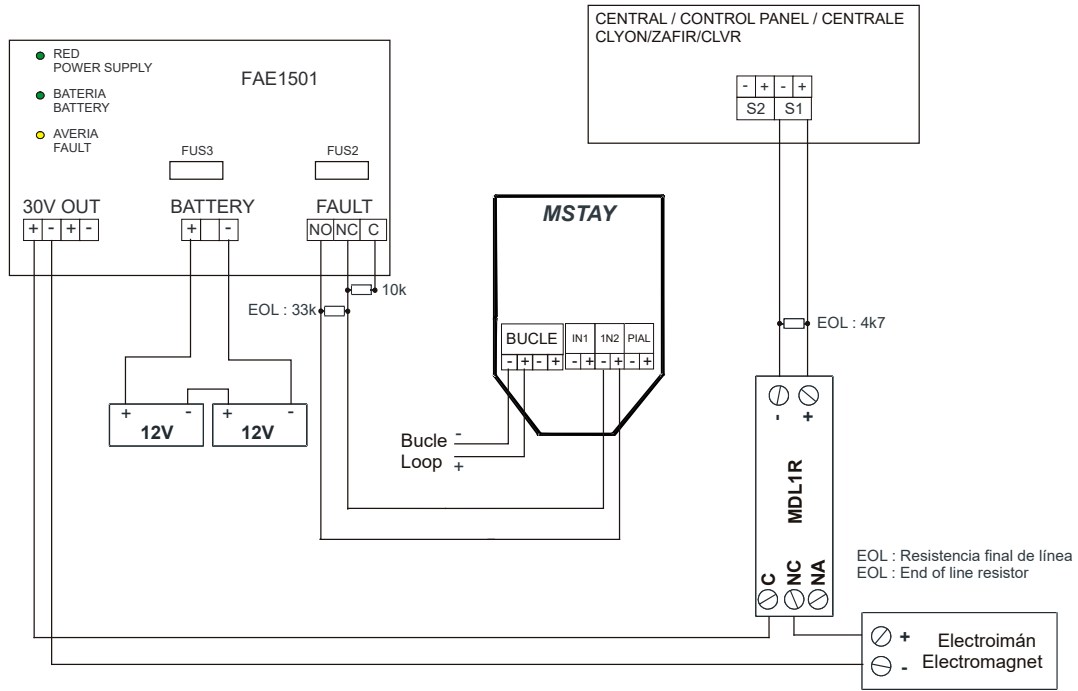

ZAFIRPWS WIRING DIAGRAM FAULT OUTPUT

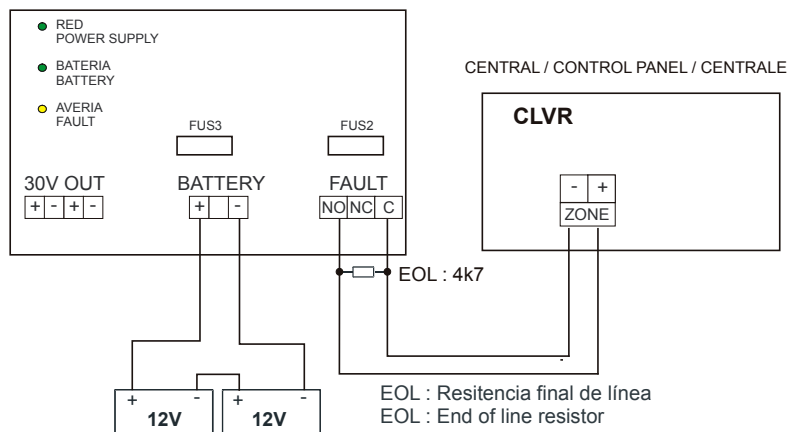



# DLR

## Optical smoke beam detectors

Optical smoke beam detectors for fire detection system consisting in a system of emitting/receiving an optical beam of infra-red light.

The installation of these detectors is ideal for large premises or for premises with very high ceilings.

There are several models:

-DLR50M and DLR100M: Motorised beam detector with separation between 50 and 100 m.

-DLRONE50 and DLRONE120: Beam detector with self-alignment, cancellation of ambient light, monitoring of the building's movements and models with separation between 50 and 120 m.

-DLRC: Conventional beam detector between 8 to 100m. Supply from control panel or external supply. Alarm and fault output connected to zone.



DLRONE50  
DLRONE120

DLRC

DLR50M  
DLR100M

	<i>DLR50M DLR100M</i>	<i>DLRONE50 DLRONE120</i>	<i>DLRC</i>
Power supply	14 to 28 Vcc	14-36 Vdc	20-28 Vdc
Standby consumption	10, 12, 14, 16 mA (for 1, 2, 3, 4 det.)	5 mA	23 mA
Alarm consumption	48 - 52 mA	33 mA	33 mA
Wavelength	850 nm	850 nm	-
Max. angle detector	± 0.3°	± 0.5°	± 0.4°
Max. angle reflector	± 5°	± 5°	-
Relay output	30 Vcc	2 A to 30 Vdc	2 A to 30 Vdc
Temperature	-10°C to +55°C	-20°C to +55°C	-10°C to +55°C
Protection	IP 54	IP 55	IP30 (IP66 with silicone sealing)
Standard	EN 54-12	EN 54-12	EN 54-12

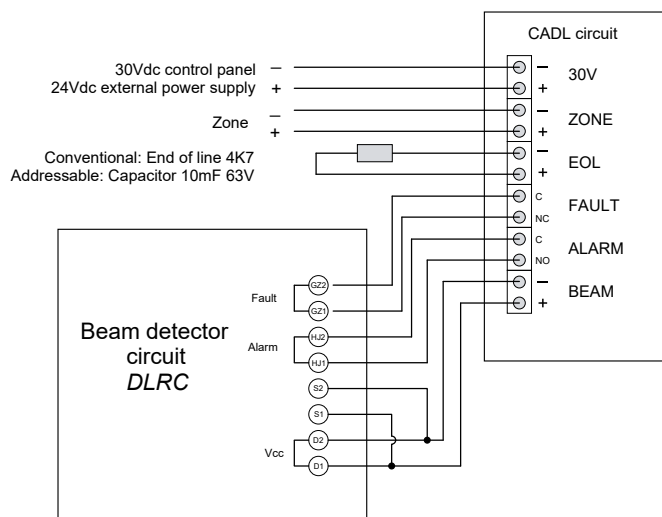

DLRC connection diagram

### ALGORITHMIC ADDRESSABLE SYSTEM

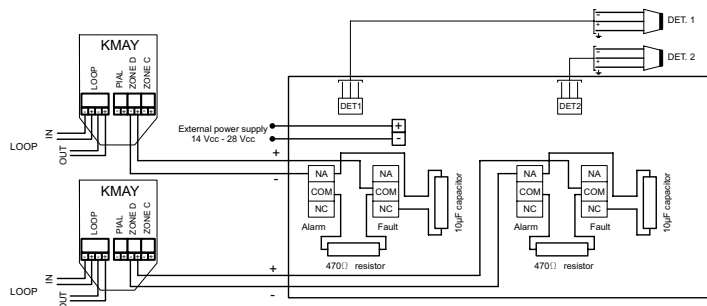

### CONVENTIONAL SYSTEM

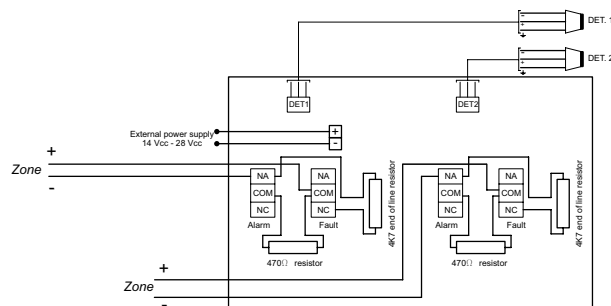

DLR50M / DLR100M connection diagram

### ALGORITHMIC ADDRESSABLE SYSTEM

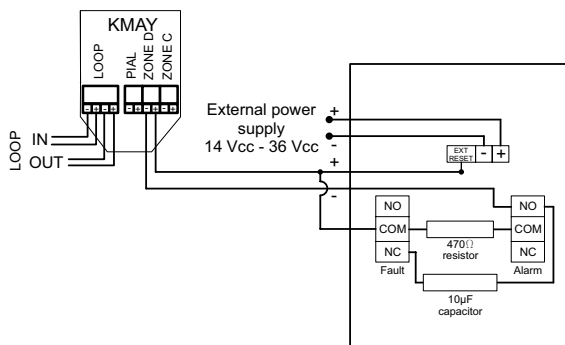

### CONVENTIONAL SYSTEM

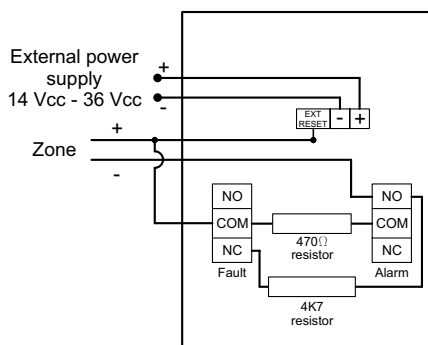

DLRONE50 / DLRONE120 connection diagram



# CTE / CTX

## Lineal heat detector



Linear heat Detector is a proprietary cable that detects the heat at any point of its length.

The sensor cable consists of two steel conductors individually insulated with a polymer sensitive to temperature. The insulated conductors are twisted together to create a spring pressure, then is wrapped with an outer cover appropriate to the environment in which must be installed in the detector.

In the calibrated temperature, heat sensitive insulating polymer yields against the pressure generated by the radiation of heat, allowing interior conductors get in touch between them and activate an alarm signal. This action occurs at any point heated within the detector cable length. It is not required to heat a specific length to activate the alarm, or you need to calibrate the system to compensate for changes in environmental temperature where it is installed.

The linear heat Detector provides the advantages of coverage of lines with sensitivity of specific points.

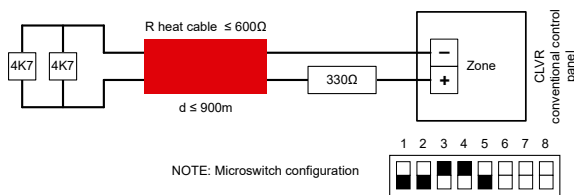

Wiring diagram with direct connection to the conventional control panel

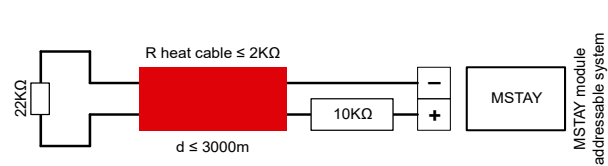

Wiring diagram with direct connection to addressable module MSTAY

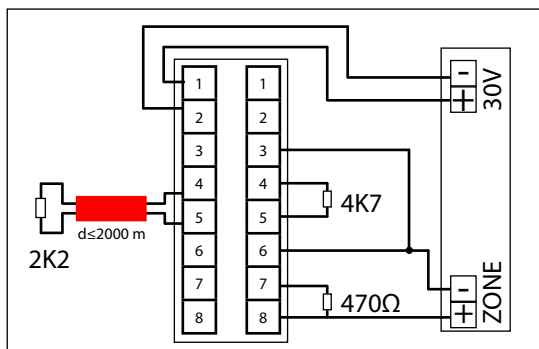

Wiring diagram with interface module

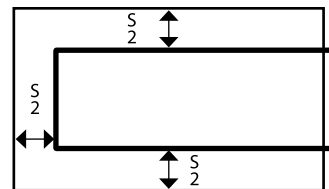

Ceiling of the protected area  
S= Generally will be 6,4 m, according to UNE 23007-14

### Type of product and temperature

Product type	Alarm T°C	Max. environ. T°C
<b>EPC</b> Various utilities/ Industrial and commercial applications	68 °C	38 °C
	88 °C	66 °C
	105 °C	79 °C
	138 °C	93 °C
	180 °C	105 °C
<b>EPR</b> Property against erosion by climate / Performance of the cover for high T°C	68 °C	38 °C
	88 °C	66 °C
	138 °C	93 °C
	180 °C	121 °C
<b>XCR</b> Industrial applications excellent resistance to the chemical abrasion	68 °C	38 °C
	88 °C	66 °C
	105 °C	79 °C
	138 °C	93 °C
<b>XLT</b> Excellent for low T°C	180 °C	121 °C
	57 °C	38 °C

### TECHNICAL FEATURES

Max. nominal voltage	30 VAC, 42 VDC
2W wire resistance	0,2 ohmios / pie. (0,656 ohm / m)
Min. radius of curvature	6,4 cm
Diameter	Nominal 4 mm
Weight	Nominal 3,6 kg / 152 m



# STF / STPR

## Probe temperature



Punctual heat detector based on a probe that allows its installation in special environments.

Depending on the protection needs, the detector can be used in:

- Aggressive environments: Model IP65.
- ATEX environments: II2GD Exd IIC T6.

Protection	IP65									
Relative humidity	98%									
Weight	400g									
Bimetal component	Nilvia (Nilvar)									
Sensor material	Steel									
Fixed calibration on request (°C)	60	71	88	107	135	163	182	232	315	385

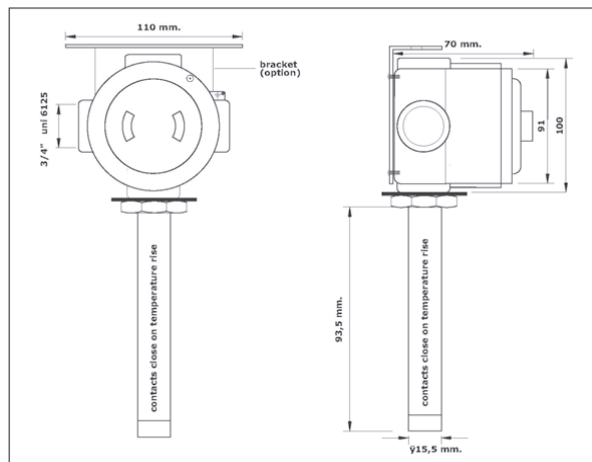

### ALGORITHMIC ADDRESSABLE SYSTEM

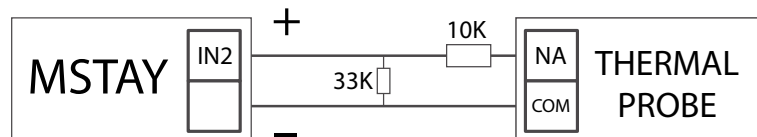

### CONVENTIONAL SYSTEM

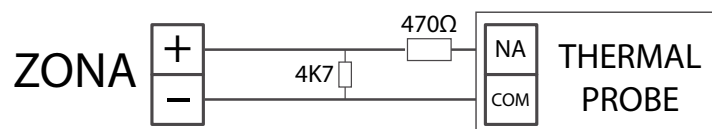



# FDINA40 FDAAT60



## Flame detector

Flame detector to protect zones with open fires.

The detector is designed to respond to the flicker frequency and wavelengths characteristic of flames

There are three types of detectors depending on the used sensors to centre in the typical specific wavelengths of the flames and generate algorithms to discriminate these flames from others lightning supplies.

- IR<sup>2</sup>: 2 IR sensors
- IR<sup>3</sup>: 3 IR sensors
- UV/IR<sup>3</sup>: 1UV sensor and 2 IR sensors.

Equally, there are an ATEX and conventional version of the previous models.

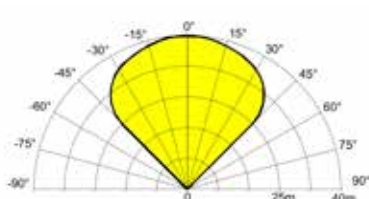

Detection field for the conventional detector

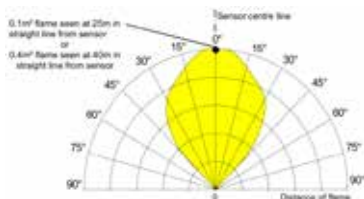

Detection field for the ATEX detector

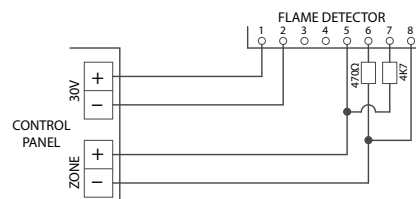

Wiring diagram

Supply voltage	14-30 VCC
Alarm current, options	28 mA, RL1 and RL2 energized 20 mA, current loop, RL1 and 2 off 9 mA, RL1 energized
Alarm indicator	Red, light-emitting diode (LED)
Alarm reset time	1 second
View range	0,1m <sup>2</sup> n-heplane at 25m
Sensibility	Class 1 (EN54-10)
View field	90° cone
Spectral response	185 a 260 nm UV / IR3 1,0 - 2,7 um
Operating temperature / Humidity	-10°C to +55°C (without ice or condensation) / 95% RH without condensation
IP protection	IP 65 (conventional) / IP 66 (ATEX)
Cover material	Die-cast Zinc Alloy, blue (conventional) Copper-free aluminium, red (ATEX)
Dimensions	142 x 108 x 82 mm (conventional) / 150 x 146 x 137 mm (ATEX)
Weight	2 KG (conventional) / 2,5 KG (ATEX)

# DAS1T / DAS4T DAS250 / DAS500

## Aspire smoke detector



A range of aspirating smoke detectors .

They detect smoke by analysing the air sucked in through holes in tubes distributed around the room to be monitored and fed to this detector.

This aspiration detector uses the latest technology in detection, avoiding false alarms, particle recognition, greater stability, sensitivity and longevity.

Typical applications for this range of detectors are: Data storage rooms, air conditioning units, machine rooms, computer rooms, equipment grilles, prison cells, air ducts, etc.

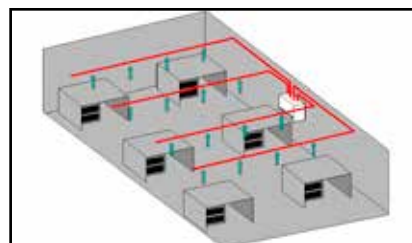

installation diagram

### TECHNICAL FEATURES

	DAS4T	DAS1T	DAS250	DAS500
Supply	24V nominal	24V nominal	24Vdc	24V nominal
Consumption	7,8 - 9,6W	9,6W	295 mA	7,8 - 9,6W
Operat. temperature	0 - 39°C	0 - 39°C	Class T3 EN 50155	Class T3 EN 50155
Humidity	10% - 95% (no cond.)	10% - 95% (no cond.)	5% - 95% (no cond.)	5% - 95% (no cond.)
IP protection	IP 40	IP 40	IP 30	IP 30
Size	350x225x135mm	350x225x135mm	256x183x92mm	256x183x92mm
Standard	EN 54-20	EN 54-20	EN 54-20	EN 54-20



# ELPCF

## Electromagnets for fire doors



ELPCF50K



ELPCF140K



ELPCF50KS



ELPCF300K

### ELPCF50K-ELPCF50KR-ELPCF50KAL-ELPCF50KALR ELECTROMAGNETS:

Electromagnetic wall retainers for fire containment doors.

- Power supply: 24V DC
- Consumption: 60 mA.
- Retention force: > 55 Kg | adjustable force.
- Unblocking push button.
- Noise suppressor.
- Anti-magnetic spring.
- UNE 1155 certificate.
- Head dimensions: 75x90x35 mm.

### ELPCF140K ELECTROMAGNET:

Electromagnetic wall retainers for fire containment doors:

- Power supply: 24 V DC
- Consumption: 70 mA.
- Retention force: > 140 Kg.
- Unblocking push button.
- Noise suppressor.
- Anti-magnetic spring.
- EN 1155 certificate.
- Head dimensions: 90x100x43 mm.

### ELPCF300K ELECTROMAGNET:

High power electromagnetic retainer for emergency and general passage doors.

- Power supply: 12 - 24V DC.
- Consumption at 12V DC: 500 mA.
- Consumption at 24V DC: 250 mA.
- Retention force: 300 Kg.
- With damping.
- Operating temperature: -10°C to +50°C.
- Protection: IP40.
- Dimensions: 250x48x25 mm.

### ELPCF600K ELECTROMAGNET:

High power electromagnetic retainer for emergency and general passage doors.

- Power supply: 12 - 24V DC.
- Consumption at 12 V DC: 500 mA.
- Consumption at 24 V DC: 250 mA.
- Retention force: 600 Kg.
- Dimensions: 265x66x41 mm.

### ELPCF50KS ELECTROMAGNET:

Electromagnetic retainer for mounting on the floor.

- Power supply: 24V DC
- Consumption: 45 mA.
- Retention force: 50 Kg.
- Protection: IP40.





**Fire protection manufacturer**  
**C/ Compositor Wagner, 8 - P.I. Can jardí**  
**08191 Rubí, SPAIN**  
**[www.cofem.com](http://www.cofem.com)**